

WATTNODE[®] LOGGER

for LONWORKS[®]

Installation and Operation Manual

- WNC-3Y-208-FT10-L
- WNC-3Y-400-FT10-L
- WNC-3Y-480-FT10-L
- WNC-3Y-600-FT10-L
- WNC-3D-240-FT10-L
- WNC-3D-400-FT10-L
- WNC-3D-480-FT10-L

Information in this document is subject to change without notice.

©2009 Continental Control Systems, LLC. All rights reserved.

Printed in the United States of America.

Document Number: WNC-FT10-L-3.64b

Revision Date: Feb. 27, 2009

Continental Control Systems, LLC.

3131 Indian Rd., Suite A

Boulder, CO 80301

(303) 444-7422

FAX: (303) 444-2903

E-mail: techsupport@ccontrolsys.com

Web: <http://www.ccontrolsys.com>

WattNode is a registered trademark of Continental Control Systems, LLC.

LONWORKS, Echelon, Neuron, LonTalk, LNS, and LonMaker are registered trademarks of Echelon Corporation.

LONMARK and the LONMARK Logo are managed, granted, and used by LONMARK International under a license granted by Echelon Corporation.

FCC Information

This equipment has been tested and complies with the limits for a Class B digital device, pursuant to part 15 of the FCC Rules. Operation is subject to the following two conditions: (1) This device may not cause harmful interference, and (2) this device must accept any interference received, including interference that may cause undesired operation.

The FCC limits are designed to provide reasonable protection against harmful interference in a residential installation. This equipment generates, uses and can radiate radio frequency energy and, if not installed and used in accordance with the instructions, may cause harmful interference to radio communications. However, there is no guarantee that interference will not occur in a particular installation. If this equipment does cause harmful interference to radio or television reception, which can be determined by turning the equipment off and on, the user is encouraged to try to correct the interference by one or more of the following measures:

- Reorient or relocate the receiving antenna.
- Increase the separation between the equipment and receiver.
- Connect the equipment into an outlet on a circuit different from that to which the receiver is connected.
- Consult the dealer or an experienced radio/TV technician to help.

Contents

Overview	5
Measurements	5
Logging	5
Communication	5
Current Transformers.....	5
Additional Literature.....	6
Front Label.....	6
Symbols.....	7
Installation	8
Precautions	8
Electrical Service Types	9
Single-Phase Two-Wire with Neutral	9
Single-Phase Three-Wire	10
Single-Phase Two-Wire without Neutral	11
Three-Phase Four-Wire Wye	12
Three-Phase Three-Wire Delta	12
Mounting	14
Selecting Current Transformers	15
Connecting Current Transformers	15
Circuit Protection.....	16
Connecting Voltage Terminals.....	16
Connecting LONWORKS Network Wiring.....	17
LONWORKS TP/FT-10 Free Topology Network	17
Wiring	18
Installation Summary	18
Service LED	18
Communication Troubleshooting	19
Measurement Troubleshooting.....	19
Network Configuration	22
Identifying the WattNode	22
WattNode Reinitialization	22
Operating Instructions.....	23
Basic Configuration	23
Verify Operation	23
Measurement Overview.....	23
Network Variables	23
Authentication	23
General Variables (NodeObject)	25
Energy Variables.....	26
Power Variables.....	27
Demand Variables (DemandMeas)	27
Voltage Variables	29
Frequency Register.....	29
Current Registers	30
Power Factor Registers.....	30
Reactive Power Registers	30
Configuration Properties	30
Calibration Configuration Properties	32

Data Logging.....	32
WattNode Errors.....	34
Maintenance and Repair.....	35
Specifications	36
Models	36
Firmware	36
Current Transformers.....	36
Measurement	37
Accuracy.....	37
Logging.....	38
Real-Time Clock.....	38
Electrical	38
Communication	39
Certifications	39
Environmental.....	39
Mechanical.....	40
Warranty.....	40

Overview

Congratulations on your purchase of the WattNode® Logger for LONWORKS watt/watt-hour transducer. The WattNode offers precision energy and power measurements in a compact package. The WattNode enables you to make power and energy measurements within existing electric service panels avoiding the costly installation of subpanels and associated wiring. It is designed for use in demand side management (DSM), sub-metering, and energy monitoring applications. Models are available for single-phase, three-phase wye, and three-phase delta configurations for voltages from 120 VAC to 600 VAC at 50 and 60 Hz.

The WattNode® Logger for LONWORKS is LONMARK® 3.4 certified, ensuring plug-and-play interoperability on LONWORKS networks.

Continental Control Systems also provides a free LNS plug-in for use with the WattNode. The WattNode plug-in simplifies configuration and browsing. For WattNode Logger models, the plug-in required to download log data.

Measurements

The WattNode Logger measures the following:

- True RMS Power - Watts (Phase A, Phase B, Phase C, Sum)
- Reactive Power - VARs (Phase A, Phase B, Phase C, Sum)
- Power Factor (Phase A, Phase B, Phase C, Average)
- True RMS Energy - Watthours (Phase A, Phase B, Phase C, Sum)
- Reactive Energy - VAR-hours (Sum)
- AC Frequency
- RMS Voltage (Phase A, Phase B, Phase C)
- RMS Current (Phase A, Phase B, Phase C)
- Demand and Peak Demand

Logging

The WattNode Logger stores all measurements to flash memory at a configurable interval from one minute to 12 hours. The log stores 24186 records; at the default 15 minute log interval, this provides more than eight months of storage.

The WattNode Logger includes a highly accurate clock with battery backup to maintain accurate date and time, so that log records have accurate timestamps. The clock is accurate to ± 2 minutes per year. The battery should last at least five years; typically ten years or more.

Communication

The WattNode communicates on a LONWORKS TP/FT-10 free topology twisted-pair network using Echelon's® LonTalk® network protocol. This interoperable network standard supports many physical media and allows easy communication between LonTalk compatible devices and monitoring computers. Network variables interface the WattNode to the network. Each device on the network may have both input and output network variables. During network setup, output network variables may be bound (connected) to input network variables of the same type. Whenever an output network variable is updated, the new value is propagated over the network, and all devices which have input network variables bound to the updated output will update their internal copies of the variable.

Current Transformers

The WattNode works with 0.333 VAC solid-core (toroidal), split-core (opening), and bus-bar current transformers (CTs). Split-core CTs offer greater ease of installation, because they can be installed without disconnecting the circuit being measured. Solid-core CTs are more compact,

generally more accurate, and less expensive, but installation requires that the measured circuit be disconnected.

Additional Literature

- WattNode Plug-in for LNS - Installation and Operation Manual
- Application Note: AN-120 Configuring LonMaker Power Units
- Handbook for Electricity Metering: Edison Electric Institute
- The Echelon® LonWorks® Products Databook: Echelon Corporation
- FTT-10A Free Topology Transceiver User's Guide, chapter 4: Network Cabling and Connection: Echelon Corporation

Front Label

This section describes all the connections, information, and symbols that appear on the WattNode front label.

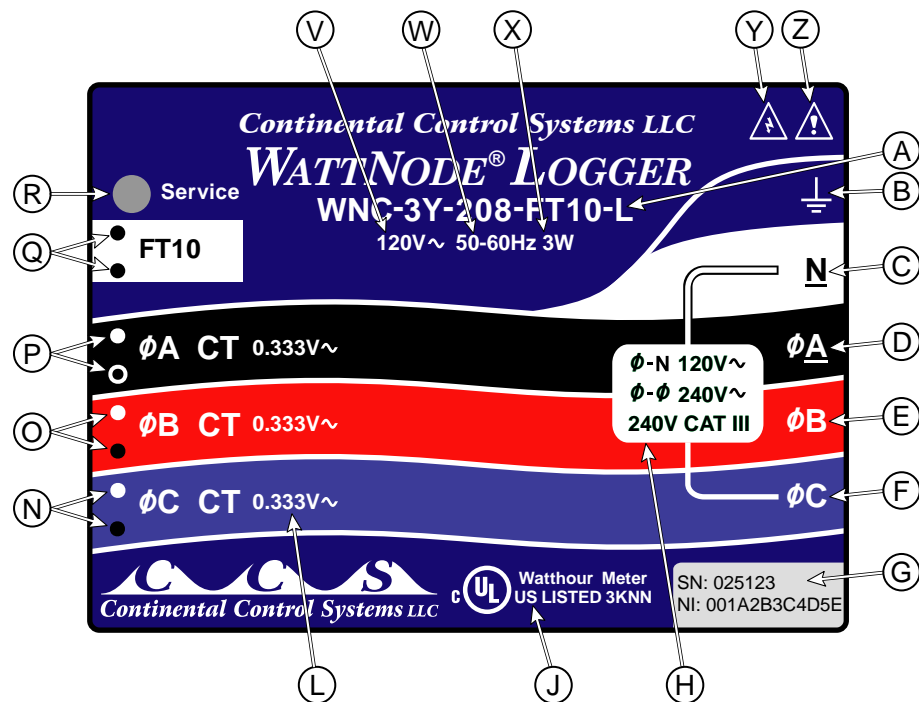

Figure 1: Front Label Diagram

A: WattNode model number. The “WNC” indicates a third generation WattNode. The “3” indicates a three phase model. The “Y” or “D” indicates wye (four-wire) or delta (three-wire) models, although delta WattNodes can measure wye circuits (the difference is in the power supply). The “208” (or other value) indicates the nominal phase-to-phase voltage. Finally, the “FT10-L” indicates LonWorks FT10 network output with logging.

B: Functional ground. This terminal should be connected to earth ground if possible. It is not required for safety grounding, but the accuracy of the WattNode may be reduced if this terminal is not connected.

C: Neutral. This terminal should be connected to neutral.

D, E, F: Mains line inputs. One or more of these terminals are connected to the mains lines. For three phase measurement, the ϕA (phase A), ϕB (phase B), and ϕC (phase C) terminals are used for the three phases. On wye WattNode models, the WattNode gets power from the **N**

and ϕA terminals. On delta WattNode models, the WattNode gets power from the ϕA and ϕB terminals.

G: Serial number and options. This small label shows the WattNode serial number and will show options if any are selected. This may show the Neuron® ID (prefixed by “NI”), which is a unique 64 bit hexadecimal number assigned to each LonWorks device.

H: Line voltage measurement ratings. This block lists the nominal phase-to-neutral “ $\phi-N 120V\sim$ ” voltage, phase-to-phase “ $\phi-\phi 240V\sim$ ” voltage, and the rated measurement voltage and category “**240V CAT III**” for this WattNode model. See **Specifications** for more information about the measurement voltage and category.

J: UL Listing mark. This shows the UL and cUL (Canadian) listing mark and number “**3KNN**”.

L: Current transformer (CT) voltage rating. These markings “**0.333V \sim** ” indicate that the WattNode must be used with current transformers that generate a full-scale output of 0.333 VAC (333 millivolts AC).

N, O, P: Current transformer (CT) inputs. These indicate the positions of the screw terminals for the current transformers connections. Note the white and black circles at the left edge of the label: these indicate the color of the CT wire that should be inserted into the corresponding screw terminal.

Q: FT10 wiring terminals. These connect to the LonWorks FT10 network.

R: LonWorks service LED. The LonWorks service LED indicates network status (see **Service LED**). Immediately below the LED on the side of the housing is the service button, used to identify the WattNode on the LonWorks network.

V: Mains supply rated voltage. This marking indicates the rated supply voltage for this WattNode. The **V \sim** indicates AC voltage. For wye WattNode models, this voltage should appear between the **N** and ϕA terminals. For delta WattNode models, this voltage should appear between the ϕA and ϕB terminals.



W: Mains frequencies. This indicates the rated mains frequencies for the WattNode.

X: Maximum rated power. This indicates the maximum rated power in watts (active power) for this WattNode model.

Y: Caution, risk of electrical shock. This symbol indicates that there is a risk of electric shock when installing and operating the WattNode if the installation instructions are not followed correctly.

Z: Attention - consult Installation and Operation Manual. This symbol indicates that there can be danger when installing and operating the WattNode if the installation instructions are not followed correctly.

Symbols

	<p>Attention - Consult Installation and Operation Manual</p>	<p>Read, understand, and follow all instructions in this Installation and Operation Manual including all warnings, cautions, and precautions before installing and using the product.</p>
	<p>Caution – Risk of Electrical Shock</p>	<p>Potential Shock Hazard from Dangerous High Voltage.</p>

Installation

Precautions



DANGER – HIGH VOLTAGE HAZARD

WARNING - These installation/servicing instructions are for use by qualified personnel only. To avoid electrical shock, do not perform any servicing other than that contained in the operating instructions unless you are qualified to do so.

Only qualified personnel or electricians should install the WattNode. Different models of the WattNode measure circuits with voltages from 120 VAC single-phase to 600 VAC three-phase. These voltages are lethal! Always adhere to the following checklist:

- 1) CCS recommends that a **licensed electrician** install the WattNode.
- 2) CCS recommends that the WattNode be installed either in an electrical enclosure (panel or junction box) or in a limited access electrical room.
- 3) Verify that circuit voltages and currents are within the proper range for the WattNode model.
- 4) Use only UL recognized current transformers (CTs) with built-in burden resistors, that generate 0.333 VAC (333 millivolts AC) at rated current. **Do not** use current output CTs such as 1 amp or 5 amp output models! See **Specifications - Current Transformers** for CT maximum input current ratings.
- 5) Ensure that the line voltage inputs to the WattNode have either fuses or circuit breakers on each voltage phase (not needed for the neutral wire). See **Circuit Protection** below for details.
- 6) Equipment must be disconnected from the HAZARDOUS LIVE voltage before access.
- 7) The terminal block screws are **not** insulated. Do not contact metal tools to the screw terminals if the circuit is live!
- 8) Do not place more than one line voltage wire in a screw terminal; use wire nuts instead. You may use more than one CT wire per screw terminal.
- 9) Before turning on power to the WattNode, ensure that all the wires are securely installed by tugging on each wire.
- 10) Do not install the WattNode where it may be exposed to temperatures below -30°C or above 55°C, excessive moisture, dust, salt spray, or other contamination. The WattNode requires an environment no worse than pollution degree 2 (normally only non-conductive pollution; occasionally, a temporary conductivity caused by condensation must be expected).
- 11) Do not drill mounting holes using the WattNode as a guide; the drill chuck can damage the WattNode housing or screw terminals.
- 12) If the WattNode is installed incorrectly, the safety protections may be impaired.

Electrical Service Types

Below is a list of service types, with connections and recommended WattNode models. Note: the WattNode ground connection improves measurement accuracy, but is not required for safety.

Model	Type	Phase to Neutral VAC	Phase to Phase VAC	Electrical Service Types
WNC-3Y-208-FT10-L	Wye	120	208–240	1 Phase 2 Wire* 120V with neutral 1 Phase 3 Wire 120V/240V 3 Phase 4 Wire 120V/208V
WNC-3Y-400-FT10-L	Wye	230	400	1 Phase 2 Wire 230V with neutral 3 Phase 4 Wire 230V/400V
WNC-3Y-480-FT10-L	Wye	277	480	3 Phase 4 Wire 277V/480V
WNC-3Y-600-FT10-L	Wye	347	600	3 Phase 4 Wire 347V/600V
WNC-3D-240-FT10-L	Delta (or Wye)	120–140	208–240	1 Phase 2 Wire 208V (No neutral) 1 Phase 2 Wire 240V (No neutral) 1 Phase 3 Wire 120V/240V 3 Phase 3 Wire 208V (No neutral) 3 Phase 4 Wire 120V/208V
WNC-3D-400-FT10-L	Delta (or Wye)	230	400	3 Phase 3 Wire 400V (No neutral) 3 Phase 4 Wire 230V/400V
WNC-3D-480-FT10-L	Delta (or Wye)	277	480	3 Phase 3 Wire 480V (No neutral) 3 Phase 4 Wire 277V/480V

*The wire count does NOT include ground. It only includes neutral (if present) and phase wires.

Table 1: WattNode Models

Single-Phase Two-Wire with Neutral

This configuration is most often seen in homes and offices. The two wires are neutral and line. For these models, the WattNode is powered from the neutral and phase A terminals.

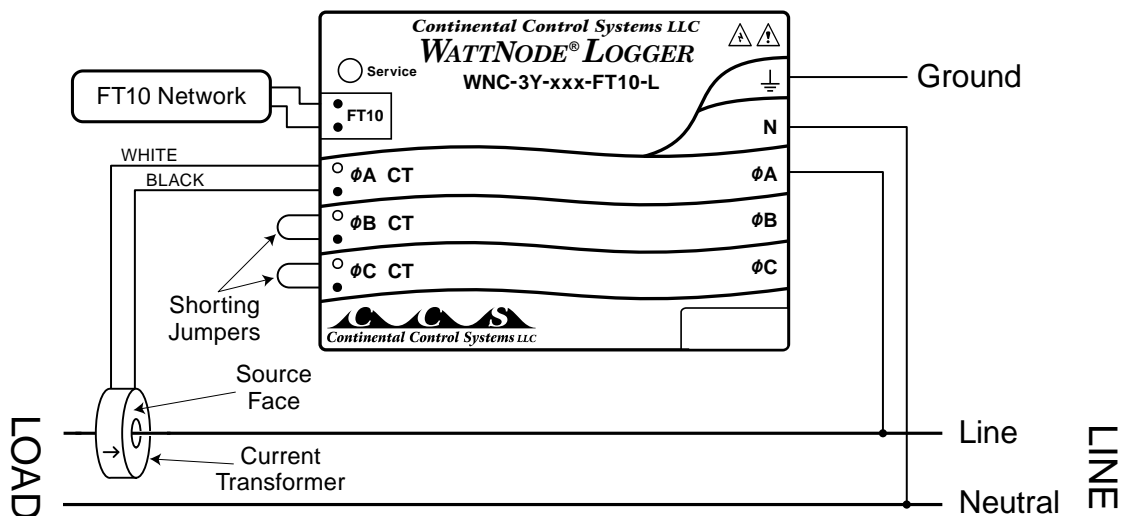

Figure 2: Single-Phase Two-Wire Connection

Recommended WattNode Models

The following table shows the WattNode models that should be used, depending on the line to neutral voltage.

Line to Neutral Voltage	WattNode Model
120 VAC	WNC-3Y-208-FT10-L
230 VAC	WNC-3Y-400-FT10-L

Single-Phase Three-Wire

This configuration is seen in residential and commercial service with 240 VAC for large appliances. The three wires are neutral and two line voltage wires with AC waveforms 180° out of phase; this results in 120 VAC between either line wire (phase) and neutral, and 240 VAC (or sometimes 208 VAC) between the two line wires (phases).

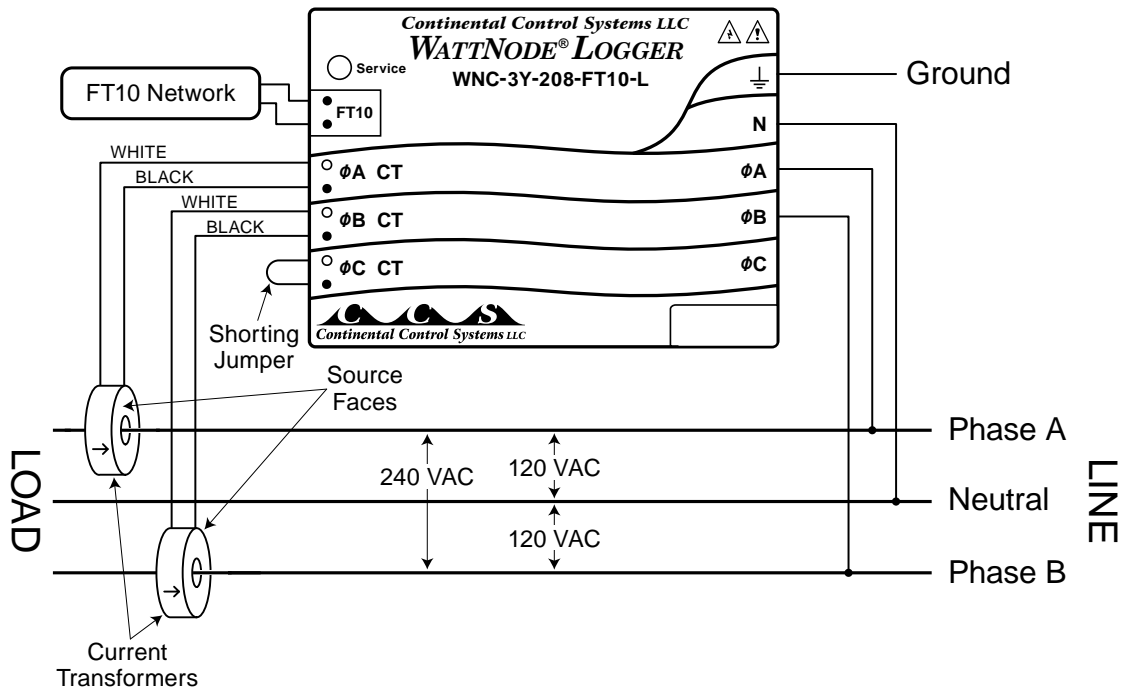

Figure 3: Single-Phase Three-Wire Connection

Recommended WattNode Models

The following table shows the WattNode models that can be used. If neutral may or may not be present, you should use the WNC-3D-240-FT10-L (see **Single-Phase Two-Wire without Neutral** below), since this model does not require neutral. If phase B may not be present, you should use the WNC-3Y-208-FT10-L (see **Single-Phase Two-Wire with Neutral** above).

WattNode Power Source	WattNode Model
Neutral and Phase A	WNC-3Y-208-FT10-L
Phase A and Phase B	WNC-3D-240-FT10-L

Single-Phase Two-Wire without Neutral

This is seen in residential and commercial service with 208 to 240 VAC for large appliances. The two wires are two line voltage wires with AC waveforms 120° or 180° out of phase. Neutral is not used. This results in 240 VAC (or 208 VAC) between the two line wires (phases). For this configuration, the WattNode is powered from the phase A “ ϕA ” and phase B “ ϕB ” terminals.

For best accuracy, we recommend connecting the WattNode neutral “**N**” terminal to earth ground. This will not cause ground current to flow because the neutral terminal is not used to power the WattNode.

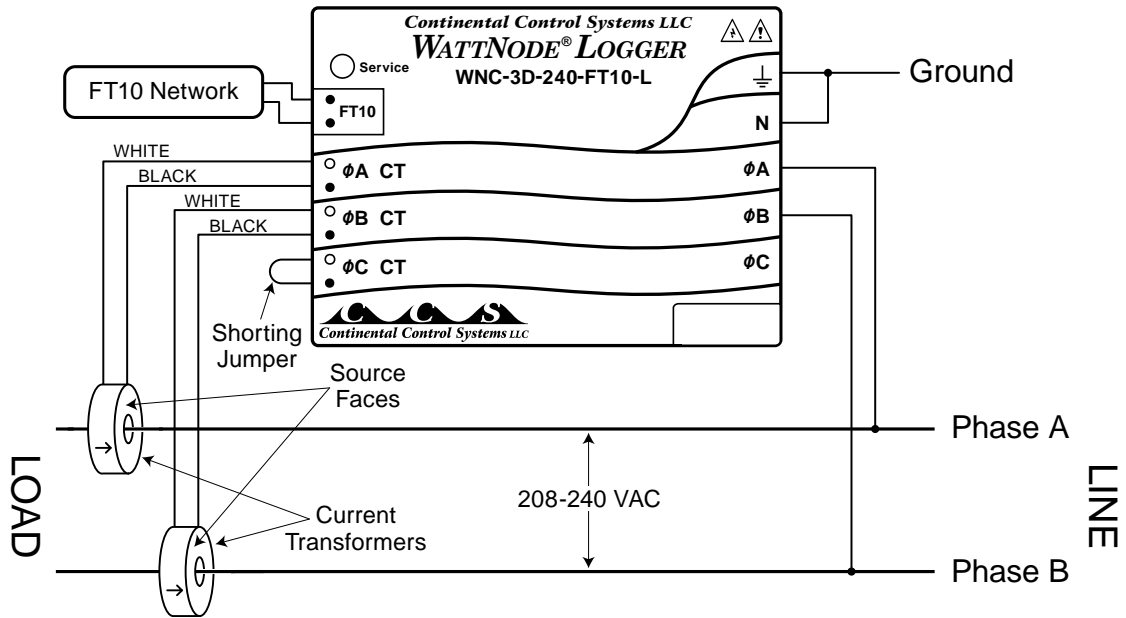

Figure 4: Single-Phase Two-Wire without Neutral Connection

Recommended WattNode Model

This configuration is normally measured with one WattNode model.

Phase-to-Phase Voltage	WattNode Model
208 - 240 VAC	WNC-3D-240-FT10-L

However, if neutral is available, then you may also use the WNC-3Y-208-FT10-L model as shown in section [Single-Phase Three-Wire](#) above.

Grounded Leg

In rare cases, one of the lines (phase A or B) may be grounded. You can check for this by using a multimeter (DMM) to measure the voltage between each phase and ground. If you see a reading between 0 and 5 VAC, that leg is probably grounded.

The WattNode will correctly measure circuits with a grounded leg.

For optimum accuracy with a grounded leg, you should connect the **N** (neutral) terminal on the WattNode to the ground terminal; this will not cause any ground current to flow because the neutral terminal is not used to power the WattNode. If you have a grounded leg configuration, you can save money by removing the CT for the grounded phase, since all the power will be measured on the non-grounded phases. We recommend putting the grounded leg on the **Phase B** input and attaching a note to the WattNode indicating this configuration for future reference.

Three-Phase Four-Wire Wye

This is typically seen in commercial and industrial environments. The wires are neutral and three power lines with AC waveforms shifted 120° between the successive phases. With this configuration, the line voltage wires may be connected to the phase A, B and C terminals in any order, **so long as the CTs are connected to matching phases**. It is important, however, that you connect the neutral line correctly. For these models, the WattNode is powered from the neutral and phase A terminals.

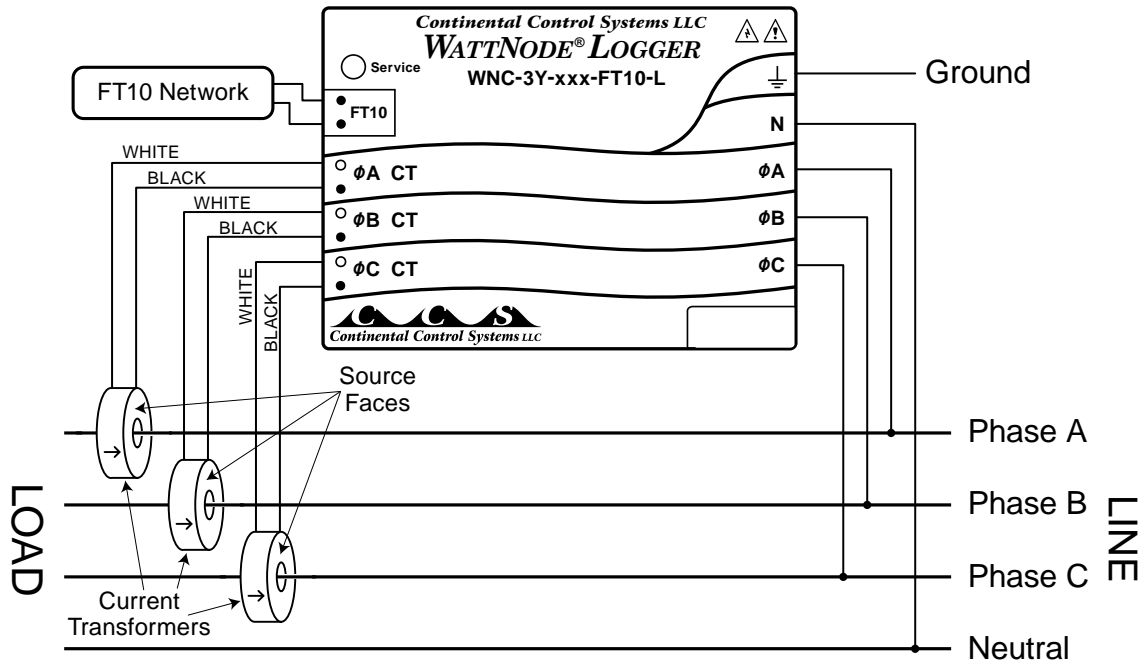

Figure 5: Three-Phase Four-Wire Wye Connection

Recommended WattNode Models

The following table shows the WattNode models that should be used, depending on the line to neutral voltage and line to line voltage (also called phase to phase voltage).

Line to Neutral Voltage	Line to Line Voltage	WattNode Model
120 VAC	208 VAC	WNC-3Y-208-FT10-L
230 VAC	400 VAC	WNC-3Y-400-FT10-L
277 VAC	480 VAC	WNC-3Y-480-FT10-L
347 VAC	600 VAC	WNC-3Y-600-FT10-L

Note: you may also use the following delta WattNode models to measure Three-Phase Four-Wire Wye circuits. The only difference is that delta WattNode models are powered from phase A and phase B, rather than neutral and phase A.

Line to Neutral Voltage	Line to Line Voltage	WattNode Model
120 - 140 VAC	208 - 240 VAC	WNC-3D-240-FT10-L
230 VAC	400 VAC	WNC-3D-400-FT10-L
277 VAC	480 VAC	WNC-3D-480-FT10-L

Three-Phase Three-Wire Delta

This is typically seen in manufacturing and industrial environments, especially with motor loads. There is no neutral wire, just three power lines with AC waveforms shifted 120° between the

successive phases. With this configuration, the line voltage wires may be connected to the phase A, B and C terminals in any order, so long as the CTs are connected to matching phases. For these models, the WattNode is powered from the phase A and phase B terminals. Note: all delta WattNode models provide an optional neutral connection, which allows delta WattNode models to measure both wye and delta configurations.

For best accuracy, we recommend connecting the WattNode neutral “N” terminal to earth ground. This is not necessary on balanced three-phase circuits, where the ground-to-phase A, ground-to-phase B, and ground-to-phase C voltages are all roughly the same. This will not cause ground current to flow because the neutral terminal is not used to power the WattNode.

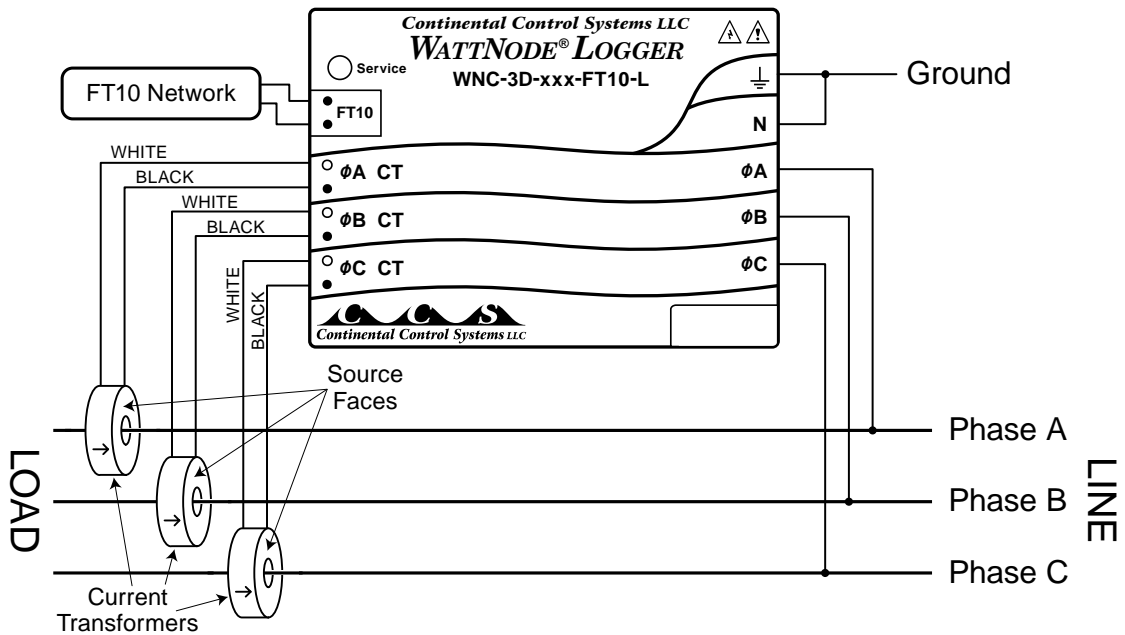

Figure 6: Three-Phase Three-Wire Delta Connection

Recommended WattNode Models

The following table shows the WattNode models that should be used, depending on the line to line voltage (also called phase to phase voltage).

Line to Line Voltage	WattNode Model
208 - 240 VAC	WNC-3D-240-FT10-L
400 VAC	WNC-3D-400-FT10-L
480 VAC	WNC-3D-480-FT10-L

Grounded Leg

In rare cases, one of the lines (phase A, B, or C) may be grounded. You can check for this by using a multimeter (DMM) to measure the voltage between each phase and ground. If you see a reading between 0 and 5 VAC, that leg is probably grounded.

The WattNode will correctly measure circuits with a grounded leg.

For optimum accuracy with a grounded leg, you should connect the **N** (neutral) terminal on the WattNode to the ground terminal; this will not cause any ground current to flow because the neutral terminal is not used to power the WattNode. If you have a grounded leg configuration, you can save money by removing the CT for the grounded phase, since all the power will be measured on the non-grounded phases. We recommend putting the grounded leg on the **Phase C** input and attaching a note to the WattNode indicating this configuration for future reference.

Mounting

Protect the WattNode from moisture, direct sunlight, high temperatures, and conductive pollution (salt spray, metal dust, etc.) If moisture or conductive pollution may be present, use a NEMA rated enclosure to protect the WattNode. Due to its exposed screw terminals, the WattNode must be installed in an electrical service panel, a junction box, or an electrical closet. The WattNode may be installed in any orientation, directly to a wall of an electrical panel or junction box.

The WattNode has two mounting holes spaced 5" (127 mm) apart (center to center). These mounting holes are normally obscured by the detachable screw terminals. Remove the screw terminals by pulling outward while rocking from end to end. The WattNode or [Figure 7](#) may be used as a template to mark mounting hole positions, but **do not drill the holes with the WattNode in the mounting position** because the drill bit or chuck may damage the WattNode housing or connectors.

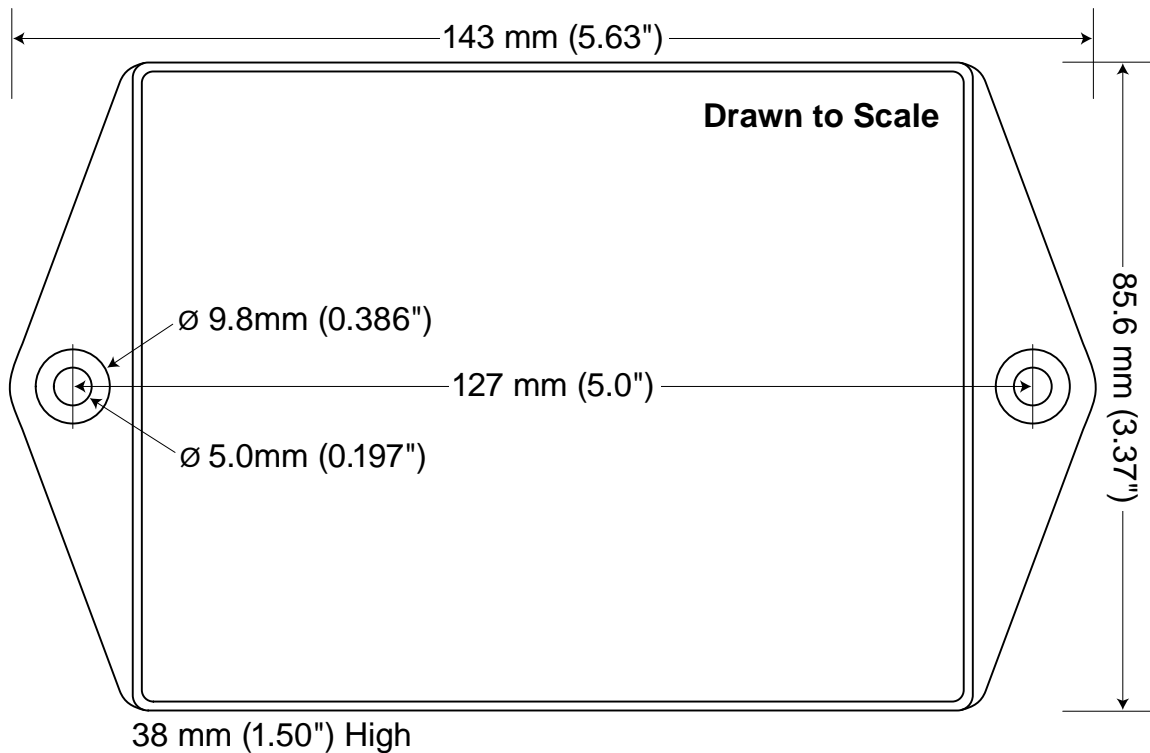

Figure 7: WattNode Dimensions

We recommend self tapping (sheet metal) screws in the following sizes (**bold** are preferred). These sizes are from the Unified Thread Standard (UTS) system used in the United States and Canada.

- Pan Head: #6 (use washer), **#8**, #10
- Round Head: #6 (use washer), **#8**, #10
- Truss Head: **#6**, #8
- Hex Washer Head (integrated washer): #6, **#8**
- Hex Head (use washer): #6, **#8**, #10

To protect the WattNode's case, use washers if the screws could pull through the mounting holes. Don't over-tighten the screws, because long term stress on the case can cause cracking.

Selecting Current Transformers

The rated current of the CTs should normally be chosen at or above the maximum current of the circuit being measured. If the circuit normally operates at a fraction of the maximum current and greatest accuracy is desired at these lower operating power levels, then CTs rated somewhat above the normal operating current may be a better choice. Take care that the maximum allowable current for the CT can not be exceeded without tripping a circuit breaker or fuse (see [Specifications - Current Transformers](#)). The WattNode accurately measures up to 120% of rated current. Above 120% of rated current, the accuracy will degrade.

We only offer AC current transformers. These cannot measure DC currents. Furthermore, significant DC currents can saturate the magnetic core, interfering with accurate AC current measurements. The vast majority of loads will only have AC current, but occasionally, you may encounter devices that draw DC current and may not be measured correctly. The most common sources of DC are devices that only use half cycles of AC current, resulting in large effective DC currents. Examples of devices that may cause DC currents include heat guns, hair dryers, and flash hot water heaters.

CTs can measure lower currents than they were designed for by passing the wire through the CT more than once. For example, to measure currents up to 1 amp with a 5 amp CT, loop the wire through the CT five times. The CT is now effectively a 1 amp CT instead of a 5 amp CT. The effective current rating of the CT is the labeled rating divided by the number of times that the wire passes through the CT.

All the CTs used with a WattNode Logger should have the same rated amps. You cannot readily mix two different current ratings (say two 200A CTs and one 50A CT), because there is a single *nciCtAmps* configuration variable that applies to all phases.

Connecting Current Transformers

- Use only UL recognized current transformers (CTs) with built-in burden resistors that generate 0.333 VAC (333 millivolts AC) at rated current. See [Specifications - Current Transformers](#) for the maximum input current ratings.
- **Do not** use current output CTs such as 1 amp or 5 amp output models: they will destroy the WattNode and present a shock hazard!
- Find the arrow or label "THIS SIDE TOWARD SOURCE" on the CT and face toward the current source: generally the circuit breaker. If CTs are mounted backwards or with their white and black wires reversed the measured power will be negative.
- To prevent magnetic interference, the CTs on different phases should be separated by at least 1 inch (25 mm). Also, the line voltage conductors for each phase should be separated by at least 1 inch (25 mm) from each other and from neutral.
- For best accuracy, the CT opening shouldn't be more than 50% larger than the conductor. If the CT opening is much bigger than the conductor, position the conductor to stay centered in the opening.
- To minimize current measurement noise, avoid extending the CT wires, especially in noisy environments. If it is necessary to extend the wires, use stranded twisted pair wire 22 - 14 AWG, rated for 600V.
- You may shorten the CT wires.
- Put jumper wires across unused CT inputs.

To connect CTs, pass the wire to be measured through the CT and connect the CT to the WattNode. **Always remove power before disconnecting any live wires.** Put the line wires through the CTs as shown in the section [Electrical Service Types](#). You may measure generated power by treating the generator as the source.

Solid-core CTs require that the wire be disconnected before passing it through the opening in the CT.

Split-core CTs can be opened for installation around a wire by pulling the removable section straight away from the rest of the CT; this may require a strong pull. The removable section only fits one way, so match up the steel core pieces when closing the CT. If the CT seems to jam and will not close, the steel core pieces are probably not aligned correctly; DO NOT FORCE together. Instead, reposition or rock the removable portion until the CT closes without excessive force. A nylon cable tie can be secured around the CT to prevent inadvertent opening.

Next, connect the CTs to the WattNode. Route the twisted black and white wires from the CT to the WattNode. Any excess length may be trimmed from the wires if desired. Strip or trim the wires to expose 1/4" (6 mm) of bare wire. The current transformers connect to the six position black screw terminal block. Connect each CT with the white wire aligned with the white dot on the label, and the black wire aligned with the black dot. Note the order in which the phases are connected, as the voltage phases **must** match the current phases for accurate power measurement.

Finally record the CT rated current as part of the installation record for each WattNode. If the wires being measured are passed through the CTs more than once, then the recorded rated CT current is divided by the number of times that the wire passes through the CT.

Circuit Protection

The WattNode is considered permanently connected equipment, because it does not use a conventional power cord that can be easily unplugged. **Permanently connected equipment must have overcurrent protection and be installed with a means to disconnect the equipment.** A switch, disconnect, or circuit breaker may be used to disconnect the WattNode. If a switch or disconnect is used, then there must also be a fuse or circuit breaker of appropriate rating protecting the WattNode.

The WattNode only draws 10-30 milliamps, so the rating of any switches, disconnects, fuses, and/or circuit breakers is determined primarily by the wire gauge used, the mains voltage, and the current interrupting rating required.

- The switch, disconnect, or circuit breaker used to disconnect the WattNode must be as close as practical to the WattNode.
- CCS recommends using circuit breakers or fuses rated for between 0.5 amps and 20 amps and rated for the mains voltages being measured.
- The overcurrent protection device (circuit breakers or fuses) must protect the ungrounded supply conductors (the mains terminals labeled ϕA , ϕB , and ϕC). If neutral is protected by the overcurrent protection device, then the overcurrent protection device must interrupt both neutral and the ungrounded conductors simultaneously.
- Any switches or disconnects should have at least a 1 amp rating and must be rated for the mains voltages being measured.
- The circuit protection / disconnect system must meet IEC 60947-1 and IEC 60947-3, as well as all national and local electrical codes.
- The line voltage connections should be made with wire rated for use in a service panel or junction box with a voltage rating sufficient for the highest voltage present. CCS recommends 14 or 12 AWG stranded wire, type MTW, THWN, or THHN, 600V. Solid wire may be used, but must be routed carefully to avoid putting excessive stress on the pluggable screw terminal.
- The WattNode has an earth connection, which should be connected for maximum accuracy. However, this earth connection is not used for safety (protective) earthing.

Connecting Voltage Terminals

Always disconnect power—by shutting off circuit breakers or removing fuses—before connecting the voltage lines to the WattNode. Connect each WattNode voltage input (green terminal block) to the appropriate phase; also connect ground and neutral (if applicable).

So long as the phase voltages are the same, the WattNode voltage inputs do not need to be connected to the same branch circuit as the load being monitored. In other words, if you have a three-phase panel with a 100A three-phase breaker powering a motor that you wish to monitor, you can power the WattNode (or several WattNodes) from a separate low current (20A) three-phase breaker in the same panel.

When connecting the WattNode, do not place more than one voltage wire in a screw terminal; use separate wire nuts or terminal blocks if needed. The screw terminals handle wire up to 12 AWG. Prepare the voltage wires by stripping the wires to expose 1/4" (6 mm) of bare wire. Connect each voltage line to the green terminal block as shown in the section **Electrical Service Types**. Verify that the voltage line phases match the CT phases. After the voltage lines have been connected, make sure both terminal blocks are securely installed on the WattNode.

If there is any doubt that the voltage rating of the WattNode is correct for the circuit being measured, then before applying power to the WattNode, disconnect the green screw terminal from the WattNode and then turn on the power. Use a voltmeter to measure the voltages (touch the screw heads) and verify that they match the values in the white box on the label.

The WattNode is powered from the voltage inputs: phase A "**ΦA**" to neutral "**N**", or **ΦA** to **ΦB** for delta models. If the WattNode is not receiving at least 85% of the nominal line voltage, it may stop operating. Since the WattNode consumes a small amount of power itself, you may wish to power the WattNode from a separate circuit or place the current transformers downstream of the WattNode, so that the power from the WattNode is not measured.

Connecting LonWORKS Network Wiring

CCS recommends that an experienced LONWORKS network installer be consulted for network design, particularly for the areas of topology, repeaters, wiring, and termination.

The FT10 twisted pair network is not polarized, so either network wire can be connected to either screw terminal. When connecting to a network, there is a maximum permissible stub length. The stub is the length of the branch wire connecting the main network to the WattNode. If the main network wiring is connected directly to the WattNode, the effective stub length is zero.

To connect the network wiring, strip the wires to expose 1/4" (6 mm) of bare wire on each of the two conductors. Then connect one conductor to each of the two terminals labeled FT10 on the black terminal block. If the WattNode is connected without a stub, then two wires can be connected to each terminal. If this is done, then take extra care with the two wires in each terminal slot, so that they are both securely tightened. Any loose wires could disable an entire section of the network.

After the network wiring has been connected, check that all the wires are securely installed by gently tugging on each wire in turn. Also check that the terminal block connectors are completely seated. At this point power may be applied to the WattNode. Note: there is no harm in applying power before making the network connections.

LonWORKS TP/FT-10 Free Topology Network

Traditional multidrop network wiring systems such as RS-485 have required a daisy-chain or bus wiring configuration to prevent interference from signal reflections. The LONWORKS TP/FT-10 free topology network transceivers include signal processing to cancel out reflections, allowing the network to be wired in arbitrary configurations: bus, star, ring, or some combination. In free topology configurations, one network terminator is recommended. In bus configurations, both ends of the bus should be terminated and stub lengths must be limited to 3m.

The following table list some recommended cables. The maximum lengths for free topology networks includes two numbers: the first is the maximum node-to-node distance, the second is the maximum total cable length. The length limits can be doubled by adding a TP/FT-10 repeater.

Description	AWG	Pairs	Shielded?	Insulation	Max Length Bus	Max Length Free Topology
CAT 5	24	4	Optional	300V	900m	250m/450m
NEMA Level IV	22	1, 2	Optional	300V	1400m	400m/500m
Belden 8471	16	1	No	300V	2700m	400m/500m
Belden 85102	16	1	No	300V	2700m	500m/500m

Table 2: Recommended FT10 Cabling

- Since the FT10 wiring may be located near line voltage wiring, use wires or cables rated for the highest voltage present, generally 300V or 600V rated wire.
- If this cable will be in the presence of bare conductors, such as bus-bars, it should be double insulated or jacketed.
- Use twisted-pair cable (unshielded or shielded) to prevent interference.

Wiring

Once you've planned the network and strung the cable, you can connect the WattNodes.

- The FT10 outputs are completely isolated from all dangerous voltages, so you can connect them at any time with the WattNode powered.
- You may put two sets of wires in each screw terminal to make it easier to daisy-chain the network from one WattNode to the next. If you do this, we recommend that you twist the wires tightly together before putting them into the screw terminal to ensure that one wire doesn't pull free, causing communication problems.

Installation Summary

- 1) Mount the WattNode.
- 2) Turn off power before installing solid-core CTs or making voltage connections.
- 3) Mount the CTs around the line wires being measured. Take care to orient the CTs facing the source.
- 4) Connect the twisted white and black wires from the CT to the black terminal block on the WattNode, matching the wire colors to the white and black dots on the label of the WattNode.
- 5) Connect the voltage wires to the green terminal block of the WattNode, and double check that the current measurement phases match the voltage measurement phases.
- 6) Connect the network (FT10) terminals of the WattNode to your FT10 network.
- 7) Apply power to the WattNode.
- 8) Verify that the LED lights correctly and doesn't indicate an error condition.

Service LED

The LoNWORKS service LED indicates the network configuration status of the WattNode. The LED should always light while the service button is being pressed: this can test that the WattNode is powered.

Many problems can be diagnosed by observing the service LED. The figure below shows the different behaviors of the WattNode service LED after power up. During normal operation, after the initial power up and network configuration, the LED should remain OFF. During some network management actions, the service LED may light or flash until the action is complete. The following terms describe the various states of the WattNode.

- **Unconfigured:** The WattNode is operating properly, but has not yet been configured (installed) by network management software.

- **Configured:** The WattNode is operating properly and has been configured by network management software. The LED may flash very briefly when power is first applied, but otherwise will stay off unless you press the service button.
- **Internal Error:** The WattNode is not functioning correctly and must be returned for service.

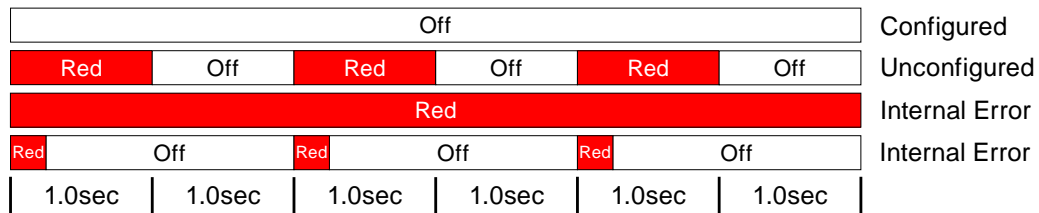

Figure 8: Service LED Behaviors

Any pattern of LED flashing not described by the figure above should also be treated as an internal error, and the WattNode returned for service. Before returning the WattNode, try cycling power at least once and observing the LED carefully. If possible, note the LED behavior, as this will help with diagnosing the problem.

Communication Troubleshooting

If you cannot configure the WattNode with your monitoring software or the WattNode stops communicating, you may have one of the following problems:

- **No power or damaged WattNode:** Test the WattNode by pressing the service button and verifying that the LED lights while the button is pressed. If the service LED does not light, check the AC voltage supplied to the WattNode to ensure power is present.
- **Wiring problem:** Check for any loose or disconnected wires. If possible, try to use a laptop computer to communicate with the WattNode at close range. If this works, then the problem may be a bad connection.
- **Electrical interference:** In some cases, electrically noisy equipment may interfere with the LONWORKS network. This can generally be determined either by noting that communication fails whenever a certain device is active, such as a high power variable speed motor drive, or by disconnecting the normal network wiring and running a very short length of wire from the WattNode to a laptop to verify that communication works. If this is the problem, you may need to use shielded network cabling, limit the length of the cabling, add terminators at both ends of the cable, or use FT10 repeaters.
- **Damaged WattNode FT10 transceiver:** In rare cases, the FT10 transceiver in the WattNode can be damaged. If the WattNode will not communicate even with a very short direct cable, then the transceiver may be damaged and you will probably need to return the WattNode for service.

Measurement Troubleshooting

There are a variety of possible measurement problems. The following procedure should help narrow down the problem. This assumes you can communicate with the WattNode and read network variables.

Voltage

Start by checking the reported voltage (*nvoVoltsA*, *nvoVoltsB*, *nvoVoltsC*) for active (connected) phases. Make sure the voltages match the expected line-to-neutral voltages (or line-to-ground for delta circuits). You should check the actual voltages present at the WattNode with a DMM (multimeter) if possible. The WattNode does not measure line-to-line voltages, so you will not be able to verify them.

- If one or more voltages are zero, then you either have a wiring problem or something is wrong with the WattNode. Verify the actual voltages with a DMM (multimeter). In rare cases, for delta circuits, one phase may be grounded, and will read zero volts.
- If one or more voltages are too low (by more than 5%), then make sure you have the correct WattNode model. For example, a WNC-3Y-208-FT10-L expects line-to-neutral voltages of 120 VAC and can measure up to about 150 VAC. If you apply 208 VAC line-to-neutral, the WattNode will read a voltage in the 150 VAC to 180 VAC range.
- If any voltages read high, then check your wiring. If the wiring is correct, contact support.
- If the voltages are within 5% of the measured (or expected) values, continue with the next step.

Power

Next, check the measured power for each active phase (*nvoPowerA*, *nvoPowerB*, *nvoPowerC*). If possible, estimate or measure the actual power. Also, make sure the load you are measuring is currently on.

- If one or more active phases are reporting zero power, then the problem is probably one of the following:
 - There is no active power (the load is off) or the power is too low to measure (generally less than 1/1000th of full-scale).
 - CT wires are not securely connected.
 - The *nciCtAmps* is set to zero (some network management tools zero configuration variables on installation).
 - The CT or its wires are damaged.
 - There is strong electrical interference, as might occur if the WattNode is in very close proximity to a variable speed drive (also called variable frequency drive or inverter).
 - The WattNode is not functioning correctly: try swapping the WattNode for another unit.
- If one or more active phases are reporting negative power:
 - The current transformer has been installed backward on the wire being measured. CTs are marked with either an arrow or a label saying “This side toward source”. If the arrow or label are not oriented toward the source of power (generally the panel or breaker), then the measured current will be inverted and the power negative. This can be fixed either by flipping the CT or by swapping the white and black wires where they enter the WattNode.
 - The current transformer white and black wires have been swapped where they enter the WattNode (at the black screw terminal block).
 - The voltage phases (green screw terminal block) are not matched up with the current phases (black screw terminal block). For example, the phase A CT is around the phase B wire.
 - This may be normal if you are measuring in an environment where power may be consumed or generated, such as a house with PV panels.
- If one or more phases are reporting low or high power:
 - Make sure the *nciCtAmps* configuration is set correctly for your current transformers.
 - Some LNS tools, such as LonMaker®, may select units of **btu/hr** for power instead of **watts**. This results in readings that appear to be 3.4X too high. See application note **AN-120 Configuring LonMaker Power Units** for more information.
 - The current transformers may have a rated current too high or too low for your application. CTs should be used between 10% and 100% of their rated current for best results. They generally work with reduced accuracy down as low as 0.5% to 0.1% of rated current.

- The CTs may not be installed properly. Check for: CTs touching each other or pre-existing CTs; CT opening too large for the conductor being measured.
- The voltage phases (green screw terminal block) are not matched up with the current phases (black screw terminal block). The easiest way to determine this is to skip ahead to the next troubleshooting section: **Power Factor and Reactive Power**.
- Interference from a variable frequency or variable speed drive: VFD, VSD, inverter, or the like. Generally, these drives should not interfere with the WattNode, but if they are in very close proximity, or if the CT leads are long, interference can occur. Try moving the WattNode at least one meter (three feet) away from any VFDs. Use short CT leads if possible. **NEVER** install the WattNode downstream of a VFD: the varying line frequency and extreme noise will cause problems!
- Our current transformers can only measure AC currents. Furthermore, strong DC currents will saturate the magnetic core of the CT, preventing an accurate measurement of the AC current. The overwhelming majority of AC powered electric devices do not draw significant DC current, so this is a rare occurrence.
- Loads with a high current crest factor (ratio of the peak current to the RMS current) can cause clipping in the WattNode measurement circuitry, resulting in lower than expected readings. You can check for this with a handheld power quality analyzer that can measure crest factor (CF) or by trying a CT with a higher rated current, which should allow the WattNode to measure the peak current accurately.
- In rare cases, the CTs are defective or mislabeled. If possible, use a current clamp to verify the current, then use a DMM (multimeter) to measure the AC voltage between the white and black wires from the CT (leave them connected to the WattNode during this test). At rated current, the CT output voltage should equal 0.333 VAC (333 millivolts AC). At lower currents, the voltage should scale linearly, so at 20% of rated current, the output voltage should be $0.20 * 0.333 = 0.0666$ VAC (66.6 millivolts AC).
- If possible, verify the expected power with a handheld power meter. Current clamps can be useful to very roughly estimate the power, but since they measure current, not power, the estimated power (voltage times current) may be off by 50% or more.

Power Factor and Reactive Power

The measured power factor and reactive power are very useful in determining if there is a phasing mismatch between the voltage and current measurement phases on the WattNode. For example, the phase A CT is around the phase B wire.

However, this troubleshooting is complicated because different loads have different typical power factors and the power factor can vary significantly for some devices, like motors, as a function of the mechanical load on the motor. Here are some general guidelines:

- **Motors, idling or with a light load:** power factor from 0.1 to 0.6, positive reactive power.
- **Motors, normal or heavy load:** power factor from 0.5 to 0.8, positive reactive power.
- **Motor with VSD:** power factor between 0.5 and 0.9.
- **Incandescent lighting:** power factor near 1.0, small negative reactive power.
- **Florescent lighting:** power factor between 0.4 and 1.0.
- **Electrical heating:** power factor near 1.0.
- **Office equipment:** power factor between 0.6 and 1.0, reactive power may be positive or negative.

If the measured power factor or reactive power appears to be outside the normal ranges, this most commonly indicates that the voltage and current phases on the WattNode are not connected properly, although some loads fall outside the normal ranges. Check the following:

- The CT connected to the **ØA CT** terminal is installed around the line wire being measured by the **ØA VAC** terminal (green terminal block).

- The CT connected to the **ΦB CT** terminal is installed around the line wire being measured by the **ΦB VAC** terminal (green terminal block).
- The CT connected to the **ΦC CT** terminal is installed around the line wire being measured by the **ΦC VAC** terminal (green terminal block).

If this doesn't solve your problem, contact technical support for more assistance.

Network Configuration

Identifying the WattNode

The WattNode supports three network identification methods.

- Press the WattNode's service button when requested by the network installation software.
- Use the WattNode's unique Neuron ID to identify the WattNode.
- Use the network wink command to light the WattNode's service LED.

Service button installation requires that the network management computer be near the WattNode during installation or that a second person can be near the WattNode to press the service button. If this technique is used, follow the procedure for installing a new node on the network in the network management software. When the software prompts you to press the service pin, press the small round button beside the black network connector (while pressed, the Service LED will light). If the network management software does not respond within several seconds, then there is probably some problem with the network (see [Communication Troubleshooting](#) above).

Neuron ID installation is performed by manually entering the WattNode's Neuron ID into the network management software during node installation. This technique allows an electrician to install and record the location and Neuron IDs of several WattNodes. Once the WattNodes are physically installed, they can be configured remotely. The Neuron ID (NI) is printed on the WattNode label.

Wink installation can be used when several WattNodes—and possibly other nodes—have been physically installed and need to be identified for the network. The network management software must be able to find unconfigured nodes on the network. When an unconfigured node is found, the network management software will be instructed to send the wink command to the node. By observing which WattNode responds to the wink command by lighting its service LED solidly for 10 seconds, the physical location of the WattNode may be matched with the network address.

The wink command may also be used after a WattNode has been configured on the network to verify its network communication and/or its physical location.

WattNode Reinitialization

The WattNode may be reinitialized to clear its configuration settings. Reinitialization can be used when the WattNode is installed in a new location or on a new network, or to restore all configuration network variables to the factory default values.

To reinitialize the WattNode, first remove power from the WattNode. Then, while holding the service button pressed, restore power. Continue holding the service button for five seconds after power is restored, then release. After a few seconds, the service LED should begin to flash (one second ON, one second OFF). Now the WattNode is unconfigured and ready to be installed.

Reinitialization deletes all network configuration, returning the WattNode to the unconfigured state. The service LED flashes slowly when the WattNode is unconfigured. All network variable bindings will be deleted and all of the configuration network variables will be restored to factory default values, except the calibration values and **nciCtAmps**. This does not clear log data, the accumulated energy or reactive energy.

Operating Instructions

Basic Configuration

The WattNode is ready to start measuring as soon as the current transformer rated amps (*nciCtAmps*) are set to the correct rated amps of your current transformers.

You should set the date and time with *nviTimeSet*, so that logged data timestamps and the peak demand timestamp will be correct.

If you are planning on using demand measurements and you don't want to use the default 15 minute interval, you should set *nciDemPerMins* as well.

Verify Operation

You should be able to read several variables to check that the WattNode is correctly installed and measuring power and energy. You should probably verify variables in the following sequence:

- ***nvoFreq* (power line frequency):** should be near 50 or 60 Hz.
- ***nvoVoltsA*, *nvoVoltsB*, *nvoVoltsC*:** should match your line-to-neutral voltage (or the line-to-ground voltage for delta models).
- ***nvoPowerA*, *nvoPowerB*, *nvoPowerC*:** should be positive (unless you are measuring something that can generate power like a PV system) and in a reasonable range for the load being measured (make sure your load is ON).

If you don't get reasonable results, check [Measurement Troubleshooting](#) above.

Measurement Overview

The WattNode performs measurements every five seconds. The measurements are used to update three types of variables:

- **Energy variables:** These accumulate up (or sometimes down) based on the consumed energy during each measurement period. Energy values are preserved across power failures.
- **Instantaneous variables:** These are non-accumulating values, like power, volts, current, etc. These are not preserved across power failures.
- **Demand variables:** these accumulate data from each measurement, but the reported demand values only update at the completion of a demand interval (or subinterval), which is typically every 15 minutes. Only the peak demand and peak demand timestamp are preserved across power failures.

Network Variables

The WattNode uses LONMARK® interoperable SNVTs (Standard Network Variable Type) and is programmed with self-documentation information. It is supplied with an external interface file (XIF), which defines all of the network variables and transceiver parameters. The XIF file may be requested by network management software during installation and is particularly useful if you wish to configure the network software for a WattNode before physically installing the WattNode.

WattNode network variable names are prefixed with three letters indicating the variable type:

- ***nvi*** - Input to the WattNode, but may also be read.
- ***nvo*** - Output from the WattNode.
- ***nci*** - Configuration network variable; normally an input to the WattNode, but can be read to determine the current configuration. All configuration variables are preserved during power outages.

Authentication

For installations where the WattNode will be used for billing, the network variables *nviTimeSet*, *nciCtAmps*, *nviResetEnergy*, *nciLogMinutes*, *nviResetPkDemand*, *nciDemPerMins*, and

nciDemSubints should be protected from unauthorized tampering. The LonTalk protocol supports authentication to prevent unauthorized access for specified variables. You must enable authentication with your network management software. Once protected, the authentication key is required to access these variables, so be sure to record the key securely.

Name	SNVT Type	Units	SNVT#	Description
General Variables (NodeObject)				
nciCtAmps	SNVT_amp_ac	amps	0	CT rated current
nciLogMinutes	SNVT_count	minutes	1	Logging interval. Default 15 minutes
nviRequest	SNVT_obj_request		2	LONMARK object request
nviTimeSet	SNVT_time_stamp		3	Set current date/time
nviFileReq	SNVT_file_req		4	File transfer request
nviFilePos	SNVT_file_pos		5	File transfer position
nviResetEnergy	SNVT_count		6	Write "1" to zero all resettable energy variables
nvoStatus	SNVT_obj_status		7	LONMARK object status
nvoFileStat	SNVT_file_status		8	File transfer status
Energy Variables				
nvoEnergySum	SNVT_elec_kwh_l	kWh	15	Total net (bidirectional) energy
nvoEnergySumNR	SNVT_elec_kwh_l	kWh	16	Total net (bidirectional) energy - non-resettable
nvoEngyPosSum	SNVT_elec_kwh_l	kWh	17	Total positive energy
nvoEngyPosSumNR	SNVT_elec_kwh_l	kWh	18	Total positive energy - non-resettable
nvoEnergyA	SNVT_elec_kwh_l	kWh	19	Net energy, phase A
nvoEnergyB	SNVT_elec_kwh_l	kWh	20	Net energy, phase B
nvoEnergyC	SNVT_elec_kwh_l	kWh	21	Net energy, phase C
nvoReacEngySum	SNVT_elec_kwh_l	kVARh	22	Total net reactive energy
Power Variables				
nvoPowerSum	SNVT_power_f	watts	34	Real power, sum of phases
nvoPowerA	SNVT_power_f	watts	35	Real power, phase A
nvoPowerB	SNVT_power_f	watts	36	Real power, phase B
nvoPowerC	SNVT_power_f	watts	37	Real power, phase C
Demand Variables (DemandMeas)				
nciDemPerMins	SNVT_count	minutes	9	Demand period: 5-720 minutes. Default 15 minutes
nciDemSubints	SNVT_count		10	Rolling demand subinterval count: 1-8. Default 1 subinterval
nviResetPkDemand	SNVT_count		11	Write "1" to reset peak demand
nvoDemand	SNVT_power_f	watts	12	Demand power (average power over demand period)
nvoDemandPk	SNVT_power_f	watts	13	Peak demand power
nvoPeakDemT	SNVT_time_stamp		14	Date/time of peak demand
Voltage Variables				
nvoVoltsA	SNVT_volt_f	volts	23	RMS voltage, phase A
nvoVoltsB	SNVT_volt_f	volts	24	RMS voltage, phase B
nvoVoltsC	SNVT_volt_f	volts	25	RMS voltage, phase C
Frequency Register				
nvoFreq	SNVT_freq_f	Hz	26	Line frequency
Current Registers				
nvoCurrentA	SNVT_amp_f	amps	27	RMS current, phase A
nvoCurrentB	SNVT_amp_f	amps	28	RMS current, phase B
nvoCurrentC	SNVT_amp_f	amps	29	RMS current, phase C

Name	SNVT Type	Units	SNVT#	Description
Power Factor Registers				
nvoPfAvg	SNVT_pwr_fact_f		30	Power factor, average
nvoPfA	SNVT_pwr_fact_f		31	Power factor, phase A
nvoPfB	SNVT_pwr_fact_f		32	Power factor, phase B
nvoPfC	SNVT_pwr_fact_f		33	Power factor, phase C
Reactive Power Registers				
nvoReacPwrSum	SNVT_power_f	VAR	38	Reactive power, sum of phases
nvoReacPwrA	SNVT_power_f	VAR	39	Reactive power, phase A
nvoReacPwrB	SNVT_power_f	VAR	40	Reactive power, phase B
nvoReacPwrC	SNVT_power_f	VAR	41	Reactive power, phase C

Table 3: Network Variables

General Variables (NodeObject)

nciCtAmps

Use ***nciCtAmps*** to specify the rated current of the attached current transformers (CTs).

To measure very low currents more accurately, you may loop the conductor being measured through the CT more than once. In this case, the effective CT amps is divided by the number of times the conductor passes through the CT. For example, if you pass the wire through a 30A CT three times, the effective CT amps becomes 10A.

In other cases, you may want to use two or more CTs in parallel on each phase. If you do this, the parallel CTs must be the same model. The effective CT amps is the rated CT amps multiplied by the number of CTs in parallel, so two 100A CTs in parallel is equivalent to a 200A CT.

nciLogMinutes

The ***nciLogMinutes*** controls the logging interval. The default value is 15 minutes, which provides more than eight months of log capacity in the flash memory. The interval can be set from one minute to 12 hours.

The WattNode keeps the logging interval synchronized to the time of day, so if the logging interval is 15 minutes, the WattNode will log at 12:00, 12:15, 12:30, etc. After a power failure, the WattNode will log at the first 15 minute synchronized time, so if power fails from 2:02 PM until 3:14 PM, the WattNode will log data at 3:15 PM.

nviRequest / nviStatus

The WattNode provides basic request and status features to meet the LONMARK requirements. The request variable ***nviRequest*** is used to request information from the WattNode. The RQ_NORMAL, RQ_UPDATE_STATUS, and RQ_REPORT_MASK requests are supported. You can make a request of the entire WattNode with using the NodeObject or one of the functional blocks.

In response to each request, the object's status is returned in ***nvoStatus***. The status variable ***nvoStatus*** also indicates if the request was made of an invalid object number, or if the object doesn't support the request made of it. The WattNode supports the following status fields:

- **object_id**: The number of the object whose status is being reported (0 = NodeObject).
- **invalid_id**: Indicates that a request was made with an invalid object number.
- **invalid_request**: Indicates that the object does not support the requested operation.

nviTimeSet

The date and time are set with ***nviTimeSet***. The WattNode uses the date and time to synchronize demand measurements to the hour, timestamp log data, and to timestamp peak demand. You

can read the WattNode's current date and time by reading this variable. The WattNode only sets **nviTimeSet** to the nearest five seconds and only updates the value every five seconds.

The WattNode Logger includes a real-time clock with battery backup to maintain accurate date and time. The clock is accurate to ± 2 minutes per year, so it should only be necessary to update **nviTimeSet** once a month or even once a year. **nviTimeSet** may be updated by a monitoring computer or it may be bound to a separate clock node on the network. The battery should last five years and typically ten years or more. The battery will last longest if the WattNode is in service (AC power applied) and at room temperature. Storing the WattNode for extended periods or operating at very cold or hot temperatures will shorten the battery life. See the **Warranty** section below for the battery warranty.

The WattNode cannot monitor the battery, so the only way to detect a drained battery is after a power failure, when the WattNode will report an error #10 "Real-time clock oscillator stopped. May indicate dead battery". In this case, the WattNode will recover the date and time from immediately before the power failure, and will continue updating the date and time. All other functionality, including data logging, will be operating normally, but with the old date and time.

To avoid a battery failure, you should plan to replace the battery at least every ten years, perhaps as often as every five years if you are operating at temperature extremes or if a failure could cause problems.

Tampering with **nviTimeSet** can affect the timing of demand measurements or logging that may be used for billing. To prevent unauthorized tampering, authentication can be enabled for **nviTimeSet**.

nviFileReq / nvoFileStat / nviFilePos

These file transfer network variables are used by LNS® network management tools to configure the WattNode and by the WattNode Plug-in for LNS to download logged data. These variables should never be directly manipulated by the operator.

nviResetEnergy

The energy variables **nvoEnergySum**, **nvoEngyPosSum**, **nvoEnergyA**, **nvoEnergyB**, **nvoEnergyC**, and **nvoReacEngySum** are all reset to zero kilowatt-hours whenever "1" is written to **nviResetEnergy**. As a security measure, two variables—**nvoEnergySumNR** and **nvoEngyPosSumNR**—are non-resettable.

If you wish to make sure energy cannot be accidentally reset or reset by an unauthorized person, enable LonTalk authentication for **nviResetEnergy**. See **Authentication** for details.

Energy Variables

Commonly known as kWh (kilowatt-hours), the energy is the integral of power over time. Many installations will only use the energy measurement. It is commonly used for billing or sub-metering. Because energy is an accumulated value, it can be used on networks that are accessed infrequently (like a utility meter that only needs to be read once a month). All energy variables are preserved through power failures.

For bidirectional applications, such as installations with PV panels, the WattNode measures the net energy sum: **nvoEnergySum** can count both up and down, depending on whether you are consuming (importing) or generating (exporting) energy. The WattNode also provides the positive energy sum: **nvoEngyPosSum** only counts up, so that you can see the total energy consumed. From these two values, you can compute the negative energy sum—the total energy generated—using the following formula (the resulting value will be positive):

$$\text{EnergyNegSum} = \text{nvoEngyPosSum} - \text{nvoEnergySum}$$

nvoEnergySum

This is the energy (kWh) sum of phase A, B, and C energies. This variable can count both up and down for bidirectional or net metering applications. If you want an energy value that can only count up, use ***nvoEngyPosSum*** instead. ***nvoEnergySum*** can be reset to zero with ***nviResetEnergy***.

nvoEnergySumNR

This is same as ***nvoEnergySum***, but can never be reset to zero (non-resettable).

nvoEngyPosSum

This is the **positive** energy (kWh) sum of phase A, B, and C energies. This variable only counts up. This is updated every five seconds by adding the net energy for phases A, B, and C for the last five seconds; if this combined total is positive, then it is added to ***nvoEngyPosSum***. ***nvoEngyPosSum*** can be reset to zero with ***nviResetEnergy***.

nvoEngyPosSumNR

This is same as ***nvoEngyPosSum***, but can never be reset to zero (non-resettable).

nvoEnergyA / nvoEnergyB / nvoEnergyC

These are the per-phase energies (kWh). These values can count both up and down for bidirectional or net metering applications. These variables can be reset to zero with ***nviResetEnergy***.

nvoReacEngySum

This is the reactive energy (kVARh) sum of phase A, B, and C reactive energies. This variable can count both up and down. Generally positive reactive energy indicates an inductive load like a motor or transformer (this may not be true if you are using a variable speed drive or inverter), while negative reactive energy indicates a capacitive load. ***nvoReacEngySum*** can be reset to zero with ***nviResetEnergy***.

Power Variables

The power variables report the real power for each phase and for the sum of all phases. They are measured every five seconds. The WattNode measures power by sampling and multiplying the instantaneous voltage and current waveforms at 5 kHz, so the power measurements are accurate even in the presence of harmonics and non-unity power factor.

All power measurements can indicate positive or negative values. Unless you are measuring power generation (as in a house with PV panels), negative power may indicate an installation problem (see [Measurement Troubleshooting](#)).

nvoPowerSum

The power sum is the sum of the power for all active phases. If one or more phases are negative, they will subtract from the total.

nvoPowerA / nvoPowerB / nvoPowerC

These are the real power values for each phase.

Demand Variables (DemandMeas)

Demand is defined as the average power over a specified time interval. Typical demand intervals are 5, 10, 15 (default), 30, 60, etc. up to 720 minutes, but the WattNode supports arbitrary demand intervals from 5 to 720 minutes (12 hours). The WattNode records the peak demand with a time stamp for metering applications where the measurements may only be accessed weekly or monthly.

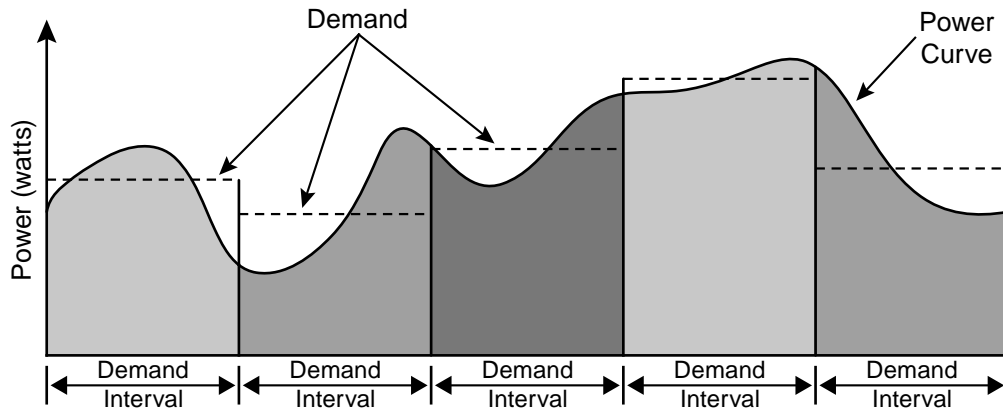

Figure 9: Demand Measurement

The WattNode also supports rolling demand (also called “sliding window”), in which the demand intervals are evenly divided into a fixed number of subintervals. At the end of each subinterval, the average power over the demand interval is computed and output. This results in better accuracy, especially for demand peaks which would not have lined up with the demand interval without subintervals. From 1 to 8 subintervals are supported, provided that the subinterval duration is at least one minute. A subinterval count of one (or zero) results in the standard demand measurement without rolling demand.

The WattNode synchronizes demand measurements to the time-of-day, so if the demand period is 15 minutes, demand measurements will complete at 11:00, 11:15, 11:30, etc. If the WattNode clock is changed (say from 11:01 to 12:01 because of daylight savings time), the WattNode will find the next synchronized time (12:15 for our example) to complete the demand measurement, so that the demand period is as close as possible to the target demand period.

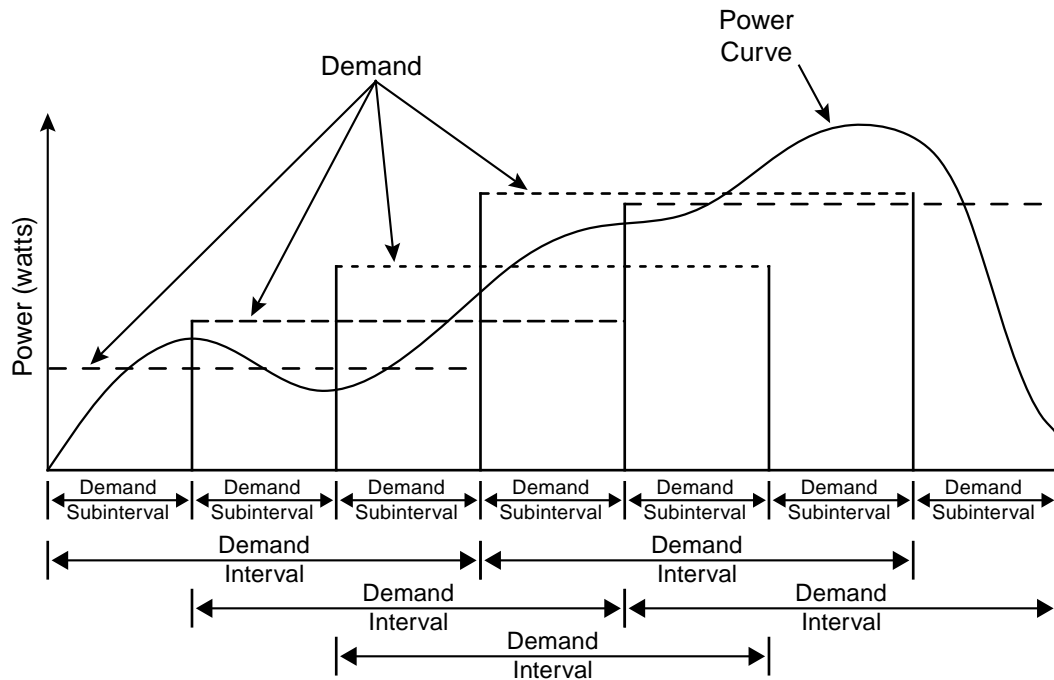

Figure 10: Rolling Demand with Three Subintervals

nciDemPerMins / nciDemSubints

The variable ***nciDemPerMins*** sets the demand interval in minutes (default 15 minutes), and ***nciDemSubints*** sets the number of demand intervals (default 1). The time period of each subinterval is the demand interval divided by the number of subintervals. Setting ***nciDemSubints*** to 1 disables subinterval computations. The demand period cannot be longer than 12 hours (720 minutes), and a demand subinterval cannot be less than 1 minutes. The ***nciDemSubints*** can be set from 1 to 8.

An example configuration could use a demand period of 60 minutes with 4 subintervals. This would result in a subinterval period of fifteen minutes. Every fifteen minutes, the average power over the last hour would be computed and reported.

nviResetPkDemand

Writing a 1 to ***nviResetPkDemand*** will zero the peak demand (***nvoDemandPk***) and the peak demand timestamp (***nvoPeakDemT***). If you wish to make sure peak demand cannot be reset by an unauthorized person, enable LonTalk authentication for ***nviResetPkDemand***. See [Authentication](#) for details.

nvoDemand

The ***nvoDemand*** variable is updated at the end of every subinterval with the average real power over a full demand interval.

The demand measurement is reset to zero by power failures and will require one full demand period after power returns before reporting full values.

nvoDemandPk

This is the largest measured demand value. It is preserved across power failures. ***nvoDemandPk*** and ***nvoPeakDemT*** can both be reset to zero by writing 1 to ***nviResetPkDemand***.

For more detailed information on demand peaks, consider using logged data, which can show every demand measurement in the log. This will allow you to easily see the peak demand for each day and month.

nvoPeakDemT

This is the date and timestamp at which the peak demand value was measured. This is cleared whenever ***nvoPeakDemT*** is reset to zero with ***nviResetPkDemand***.

Voltage Variables

nvoVoltsA / nvoVoltsB / nvoVoltsC

These are the RMS AC voltages for each phase. These are measured relative to the neutral connection on the WattNode. If neutral is not connected, then these are measured relative to the ground connection on the WattNode. The WattNode does not measure line-to-line voltages.

Voltage phases that are not connected may report small random voltages, but the WattNode treats any phase reporting less than 20% of the nominal VAC as inactive and will not measure power or energy on inactive phases.

Frequency Register

nvoFreq

The WattNode measures the AC line frequency in Hertz. All active phases must have the same line frequency; otherwise this value will be erratic or incorrect.

Current Registers

nvoCurrentA / nvoCurrentB / nvoCurrentC

The WattNode measures the RMS current for each phase. This is an indirect measurement and so not as accurate as power and energy. The reported current will always be positive.

Power Factor Registers

The power factor is the ratio of the real power to the apparent power. Resistive loads, like incandescent lighting and electric heaters, should have a power factor near 1.0. Power-factor corrected loads, like computers, should be near 1.0. Motors can have power factors from 0.2 to 0.9, but are commonly in the 0.5 to 0.7 range.

If the power for a phase is negative, the power factor will also be negative. The reported power factor will be 1.0 for any phases measuring zero power, and will be 0.0 for any inactive phases (line voltage below 20% of nominal VAC).

nvoPfAvg

This is the average power factor for active phases (line voltage above 20% of nominal VAC).

nvoPfA / nvoPfB / nvoPfC

These are the power factor values for each phase.

Reactive Power Registers

Reactive power is also known as VARs. Inductive loads, like motors, generate positive reactive power, while capacitive loads generate negative reactive power. Reactive power transfers no net energy to the load and generally is not metered by the utility. Loads with high reactive power relative to the real power will tend to have lower power factors.

nvoReacPwrSum

The ***nvoReacPwrSum*** is the sum of the reactive power of active phases. This can include negative values, so if one phase is negative, it will reduce the reported ***nvoReacPwrSum***.

nvoReacPwrA / nvoReacPwrB / nvoReacPwrC

These are the per-phase reactive power measurements.

Configuration Properties

The WattNode also includes configuration properties (CPs), which are similar to “***nci***” network variables, but consume fewer resources. The WattNode uses CPs for less commonly accessed quantities, including factory calibration. These are preserved over power outages.

For convenience, there are a few variables that can be accessed as either a SNVT or a CP: ***nciCtAmps***, ***nciLogMinutes***, ***nciDemPerMins***, and ***nciDemSubints***. These four variables are documented above as network variables.

Calibration related CPs are normally hidden and should not be changed except by the factory.

Name	CP Type	Functional Block	Description
General Configuration			
nciCtAmps	UCPTctAmps	NodeObject	CT rated current, amps
nciLogMinutes	UCPTlogIntervalMins	NodeObject	Logging interval. Default 15 minutes
nciLocation	SCPTlocation	NodeObject	WattNode location, 30 character string
nciDevMajVer	SCPTdevMajVer	NodeObject	WattNode firmware, major version
nciDevMinVer	SCPTdevMinVer	NodeObject	WattNode firmware, minor version
nciModel	UCPTmodel	NodeObject	WattNode model
nciSerialNumber	UCPTserialNumber	NodeObject	WattNode serial number
Measurement Configuration			
nciMaxSendT	SCPTmaxSndT		Configure update rate for all measurement SNVTs. Default 5 seconds.
Demand Configuration			
nciDemPerMins	UCPTdemandPeriodMins	DemandMeas	Demand period: 5-720 minutes. Default 15 minutes
nciDemSubints	UCPTdemandSubintervals	DemandMeas	Rolling demand subinterval count: 1-8. Default 1 subinterval
Calibration			
nciFactoryCmd	UCPTfactoryCommand	WattnodeCal	Factory calibration commands
nciCalPowerA	UCPTcalPowerA	WattnodeCal	Power calibration, phase A
nciCalPowerB	UCPTcalPowerB	WattnodeCal	Power calibration, phase B
nciCalPowerC	UCPTcalPowerC	WattnodeCal	Power calibration, phase C
nciCalReactiveA	UCPTcalReactiveA	WattnodeCal	Reactive power calibration, phase A
nciCalReactiveB	UCPTcalReactiveB	WattnodeCal	Reactive power calibration, phase B
nciCalReactiveC	UCPTcalReactiveC	WattnodeCal	Reactive power calibration, phase C
nciCalVoltA	UCPTcalVoltA	WattnodeCal	Voltage calibration, phase A
nciCalVoltB	UCPTcalVoltB	WattnodeCal	Voltage calibration, phase B
nciCalVoltC	UCPTcalVoltC	WattnodeCal	Voltage calibration, phase C
nciPhaseAdjA	UCPTphaseAdjA	WattnodeCal	Phase angle adjustment, phase A
nciPhaseAdjB	UCPTphaseAdjB	WattnodeCal	Phase angle adjustment, phase B
nciPhaseAdjC	UCPTphaseAdjC	WattnodeCal	Phase angle adjustment, phase C
nciCreepLimit	UCPTcreepLimit	WattnodeCal	Creep limit
nciNominalVac	UCPTnominalVolt	WattnodeCal	Nominal line-to-neutral VAC
nciMinVac	UCPTminVolt	WattnodeCal	Minimum line-to-neutral VAC for active phases

Table 4: Configuration Properties

nciLocation (SCPTlocation)

This read/write property can hold a 30 character string describing the WattNode's location or other useful information.

nciDevMajVer / nciDevMinVer (SCPTdevMajVer / SCPTdevMinVer)

These are the major and minor version numbers of the WattNode firmware. For example, if *nciDevMajVer* = 3 and *nciDevMinVer* = 64, then the firmware version is 3.64.

nciModel (UCPTmodel)

This read-only string indicates the WattNode model. Example: WNC-3Y-208-FT10-L.

nciSerialNumber (UCPTserialNumber)

This is the WattNode's serial number.

nciMaxSendT (SCPTmaxSndT)

This property is used to configure the rate at which the WattNode updates measurement network variables, such as *nvoPowerSum*. The update rate for all measurements except demand are controlled by *nciMaxSendT*. This setting is most useful if you use bound network variables, because it will control the rate at which network variable updates are transmitted over the network.

If you are polling network variables from a PC (or LonWorks data logger), you should leave *nciMaxSendT* at the default five seconds and adjust the polling rate at the PC instead.

The default update rate is five seconds, which is also the fastest update rate. The slowest update rate is limited to 12 hours. *nciMaxSendT* is actually a data structure containing fields for days, hours, minutes, seconds, and milliseconds. The WattNode only uses the fields for hours, minutes, and seconds.

nciCreepLimit (UCPTcreepLimit)

Creep refers to the situation where the wheel on an traditional electro-mechanical energy meter moves even though there is no power being consumed. The WattNode has no wheel, but still must address this situation. All electrical systems have some noise, which can cause small readings in the absence of any power consumption. In order to prevent these bogus readings due to noise, the WattNode forces the measured power and reactive power values to zero if the readings fall below a certain fraction of full-scale power. This also forces the associated energy values to zero for the measurement interval. This is performed independently for each measurement phase using the following equation.

$$\text{MinimumPower} = \text{FullScalePower} / \text{CreepLimit}$$

Any measured power or reactive power below *MinimumPower* is forced to zero. *FullScalePower* is defined as the nominal phase-to-neutral VAC (see [Specifications](#)) multiplied by the full-scale (rated) CT current.

Generally, the default value of 1500 (which sets the creep limit to 1/1500th of full-scale power) works fine. Sometime, however, in electrically noisy environments, you may see non-zero power readings when you are certain the power is zero. You can adjust the creep limit upward to eliminate this problem. For example, if you want to adjust the creep limit to 1/500th of full-scale (0.2%), just set *CreepLimit* to 500.

Calibration Configuration Properties

All the other configuration properties (CPs) are for calibration or factory use only. Most network management tools will hide them, because they are flagged for manufacturer use only. They are protected from being changed in the field.

Data Logging

The WattNode Logger adds two features not found in the WattNode Plus: a 2MB flash memory and a real-time clock to ensure accurate timestamps for log data. The flash memory holds 24186 log records. Each record stores the following fields:

- **Record Number***: Every log record is assigned a unique number starting with “1”. This helps uniquely identify each log record, even if the clock is changed (as for daylight savings). The maximum value is two billion, so the record number would take 4000+ years to overflow.
- **Status***: The status field can indicate if one or more of the following events occurred during the log interval:
 - **Power failure**: this is the first log record after a power failure.
 - **Clock change**: the date / time was changed with *nviTimeSet*.
 - **Calibration change**: the calibration was changed: this should never occur in the field.

- **Configuration change:** one of the following was changed: *nciDemPerMins*, *nciDemSubints*, *nciLogMinutes*, *nciCtAmps*, *nciCreepLimit*.
- **WattNode online:** The WattNode was brought online by a network management tool.
- **WattNode reset:** The WattNode was reset, generally by a network management tool.
- **Internal error:** The WattNode experienced an internal error or warning. Use the WattNode Plug-in or your network management tool to check the last error. See **WattNode Errors**.
- **Date / Time*:** This stores the date and time at the completion of the log interval.
- **Log Seconds*:** This records the number of seconds of data included in the log record. Normally, this should match the log interval (ie. if the log interval is 15 minutes, the log seconds should be 900 seconds). However, if the clock is changed with *nviTimeSet* or this is the first log record after a power failure, the log seconds may be different.
- **Demand*:** This stores the most recent demand measurement. Generally you will want to configure *nciLogMinutes* to match *nciDemPerMins*, so that demand intervals and log intervals occur at the same time. If you do this, the WattNode will keep them synchronized so that every time a new demand value is computed, the WattNode will immediately create a log record with the new demand value.
- **Energy Sum*:** Value of *nvoEnergySum* at the log time.
- **Energy Positive Sum:** Value of *nvoEngyPosSum* at the log time.
- **Energy A, B, C:** Values of *nvoEnergyA*, *nvoEnergyB*, and *nvoEnergyC* at the log time.
- **Reactive Energy Sum:** Value of *nvoReacEngySum* at the log time.
- **Volts A, B, C:** Values of *nvoVoltsA*, *nvoVoltsB*, and *nvoVoltsC* at the log time.
- **Frequency:** Value of *nvoFreq* at the log time.
- **Power A, B, C:** Values of *nvoPowerA*, *nvoPowerB*, and *nvoPowerC* at the log time.
- **Reactive Power A, B, C:** Values of *nvoReacPwrA*, *nvoReacPwrB*, and *nvoReacPwrC* at the log time.
- **CRC:** This is a cyclic redundancy check, used to ensure that the log record isn't corrupt.

All fields are stored in the flash, but records can be retrieved as “Long” or “Short” records. Short records only include the fields above marked with “*”. It is about three times faster to retrieve short records, so if you don't need the extra fields, you should retrieve short records.

The WattNode never deletes log records, except when the log fills up, at which point, the WattNode will start overwriting the oldest log records with new data. So at any time, the WattNode will have the last 24186 log records in its flash (unless it hasn't been in service long enough to fill the log).

The WattNode synchronizes logging to the time of day. For example, if you specify a 15 minute log interval with *nciLogMinutes*, the WattNode will log at 1:00, 1:15, 1:30, 1:45, 2:00, etc. If power fails and then recovers, the WattNode will log at the next synchronized time. So if power fails at 2:08 and recovers at 2:26, the WattNode will log data at 2:30 (there will be no log record for 2:15 because power was off at that time).

The following table shows the total log capacity as the log interval varies. It also shows the download time for one month of log data for both long and short log records.

Log Interval (Minutes)	Log Capacity	Log Records per Month	Download Time, Month of Short Records	Download Time, Month of Long Records
1 minute	2.4 weeks	24186 [†]	28 minutes [†]	88 minutes [†]
2 minutes	4.8 weeks	21960	25 minutes	80 minutes
5 minutes	12 weeks	8784	10 minutes	32 minutes
10 minutes	5.5 months	4392	5 minutes	16 minutes
15 minutes	8.2 months	2928	3.4 minutes	11 minutes
30 minutes	16.5 months	1464	1.7 minutes	6 minutes
1 hour	33 months	732	1 minute	3 minutes
2 hours	5.5 years	366	26 seconds	1.5 minutes
4 hours	11 years	183	13 seconds	40 seconds
6 hours	16.5 years	122	9 seconds	27 seconds
12 hours	33 years	61	5 seconds	14 seconds

Table 5: Log Capacity vs. Log Interval

[†]Note: At a one minute log interval, the log can only hold 2.4 weeks of data, so the “Records per Month” and download times are for 2.4 weeks of data, not a full month of data.

Log data is retrieved using the WattNode Plug-in for LNS, which in turn uses the LonTalk file transfer protocol to download the data. The file transfer protocol over the TP/FT-10 transceiver is relatively slow (~22kB per minute), so downloading a full log with 24186 records takes roughly 30 minutes if you are downloading short records and 90 minutes for long records. Therefore, you may want to select the longest reasonable log interval to minimize log download times. The plug-in can automatically download only new records, making the download much faster if you download regularly.

WattNode Errors

The WattNode tracks internal errors and warnings. The most recent error is logged and preserved over power failures so that it can be recovered by the WattNode Plug-in or by any network management tool. If you see error #10, contact CCS about having the real-time clock battery replaced. For errors, contact CCS, because the WattNode may need service. Warnings can generally be disregarded unless they occur repeatedly.

- **0:** No error
- **1:** Error: Could not recover non-volatile data; energy and peak demand lost.
- **7:** Warning: Attempted to set *nviTimeSet* to invalid date/time.
- **10:** Error: Real-time clock oscillator stopped. This generally indicates a dead real-time clock battery.
- **11, 12:** Error: Real-time clock not responding.
- **13:** Error: Real-time clock write verify failed.
- **14:** Error: Real-time clock initialize verify failed.
- **15:** Error: Bad CRC on real-time clock extra data. Date may be corrupt.
- **16:** Warning: Missed one or more ticks from real-time clock.
- **17:** Error: Unrecognized logging flash version response.
- **18:** Error: Could not recover log status information; logging disabled.
- **19:** Warning: Could not recover calibration from FRAM - used EEPROM backup copy.

Maintenance and Repair

The WattNode requires no routine maintenance other than replacing the real-time clock battery every 5-10 years. The WattNode must be returned to the factory for battery replacement. There are no fuses in the WattNode. It contains no user serviceable or replaceable parts. There are no diagnostic tests that can be performed by the user, other than checking for errors via the Lon-Works interface and with the service LED.

The WattNode should not normally need to be cleaned, but if cleaning is desired, power must be disconnected first and a dry cloth or brush should be used.

The WattNode is not user serviceable. In the event of any failure, the WattNode must be returned for service. In the case of a new installation, follow the instructions in sections **Service LED** and **Measurement Troubleshooting** before returning the WattNode for service, to ensure that the problem is not connection related.

Specifications

Models

Model	Nominal VAC phase-to-neutral	Nominal VAC phase-to-phase	Phases	Wires
WNC-3Y-208-FT10-L	120	208–240	3	4
WNC-3Y-400-FT10-L	230	400	3	4
WNC-3Y-480-FT10-L	277	480	3	4
WNC-3Y-600-FT10-L	347	600	3	4
WNC-3D-240-FT10-L	120*	208–240	3	3–4
WNC-3D-400-FT10-L	230*	400	3	3–4
WNC-3D-480-FT10-L	277*	480	3	3–4

Table 6: WattNode Models

**Note: the delta models have an optional neutral connection that may be used for measuring wye circuits. The delta WattNode models use the phase A and phase B connections to power the WattNode.*

Firmware

Firmware Version(s): 3.63, 3.64

XIF file(s): WNC-FT-Log-363.XIF, WNC-FT-Log-364.XIF (these XIF file versions are identical)

LONWORKS Program ID: 8:00022:1500:0A:04:0A

LONMARK Certification Version: 3.4

Current Transformers

The WattNode uses CTs with built-in burden resistors generating 0.333 VAC at rated AC current. The maximum input current rating is dependent on the CT frame size (see the tables below). Exceeding the maximum input current rating may damage CTs.

The WattNode should only be used with UL recognized current transformers, which are available from Continental Control Systems. Using non-approved transformers will invalidate the WattNode's UL listing. The following sections list approved UL recognized current transformers.

Split-Core CTs

Also called “opening” current transformers. These are UL recognized under UL file number E96927: CTS-0750-xxx, CTS-1250-xxx, CTS-2000-xxx, where **xxx** indicates the full scale current rating between 0005 and 1500 amps.

The accuracy and phase angle of the split-core CTs are specified from 10% to 130% of rated current. These CTs do not measure DC current and the accuracy will be degraded in the presence of DC current. Some low current split-core CTs have unspecified phase angle errors. The following table shows the available split-core CTs. The CT suffix **xxx** is the rated current.

Model	Inside Diameter	Rated Amps	Accuracy / Phase Angle	Maximum Amps
CTS-0750-xxx	0.75" (19.0mm)	5, 15, 20, 30, 50	±1% / not spec.	200
CTS-0750-xxx	0.75" (19.0mm)	70, 100, 150	±1% / <2°	200
CTS-1250-xxx	1.25" (31.7mm)	70, 100	±1% / not spec.	600
CTS-1250-xxx	1.25" (31.7mm)	150, 200, 250, 300, 400, 600	±1% / <2°	600
CTS-2000-xxx	2.00" (50.8mm)	600, 800, 1000, 1200, 1500	±1% / <2°	1500

Table 7: Split-core CTs

Solid-Core CTs

Also called “toroid” or “donut” current transformers. These are UL recognized under UL file number E96927: CTT-0750-100N, CTT-1250-400N, CTT-0300-030N, CTT-0500-060N, CTT-1000-200N, CTT-0300-005N, CTT-0300-015N, CTT-0500-050N, CTT-0500-030N, CTT-0500-015N, CTT-0750-070N, CTT-0750-050N, CTT-0750-030N, CTT-1000-150N, CTT-1000-100N, CTT-1000-070N, CTT-1000-050N, CTT-1250-300N, CTT-1250-250N, CTT-1250-200N, CTT-1250-150N, CTT-1250-100N, CTT-1250-070N.

The accuracy of the solid-core CTs is specified from 10% to 130% of rated current. The phase angle error is specified at 50% of rated current. These CTs do not measure DC current and the accuracy will be degraded in the presence of DC current. The following table shows the available solid-core CTs. The CT suffix **xxx** is the rated current. The “N” at the end of the part number indicates a nickel core material, which is the only core material available for our solid-core CTs.

Model	Inside Diameter	Rated Amps	Accuracy / Phase Angle	Maximum Amps
CTT-0300-xxxN	0.30" (7.6mm)	5, 15, 20, 30	±1% / <1°	30
CTT-0500-xxxN	0.50" (12.7mm)	15, 20, 30, 50, 60	±1% / <1°	60
CTT-0750-xxxN	0.75" (19.0mm)	30, 50, 70, 100	±1% / <1°	100
CTT-1000-xxxN	1.00" (25.4mm)	50, 70, 100, 150, 200	±1% / <1°	200
CTT-1250-xxxN	1.25" (31.7mm)	70, 100, 150, 200, 250, 300, 400	±1% / <1°	400

Table 8: Solid-core CTs

Measurement

Creep Limit (Default): 0.067% (1/1500th) of full-scale. Whenever the measured power or reactive power for a phase drops below the creep limit, the reported power or reactive power for the phase will be forced to zero. Also, if the line voltage for a phase drops below 20% of nominal VAC, all outputs for the phase will be forced to zero. These limits prevent spurious readings due to measurement noise. The creep limit can be customized (see [nciCreepLimit](#)).

Update Rate: 5.0 seconds. Internally, all measurements are performed at this rate.

Over-Voltage Limit: 125% of nominal VAC. Extended over-voltage operation can damage the WattNode and void the warranty.

Over-Current Limit: 120% of rated current. Exceeding 120% of rated current will not harm the WattNode but the current and power will not be measured accurately.

Accuracy

The following accuracy specifications do not include errors caused by the current transformers.

Condition 1 - Normal Operation

Line voltage: 80% - 115% of nominal

Power factor: 1.0

Frequency: 48 - 62 Hz

Ambient Temperature: 25°C

Current: 5% - 100% of rated current

Accuracy: ±0.5% of reading

Condition 2 - Low Current

All conditions the same as Condition 1 except:

Current: 1% - 5% of rated current

Accuracy: ±1.0% of reading

Condition 3 – Very Low Current

All conditions the same as Condition 1 except:

Current: 0.2% - 1% of rated current

Accuracy: $\pm 3.0\%$ of reading

Condition 4 - High Current

All conditions the same as Condition 1 except:

Current: 100% - 120% of rated current

Accuracy: $\pm 1.0\%$ of reading

Condition 5 - Low Power Factor

All conditions the same as Condition 1 except:

Power factor: 0.5 (± 60 degree phase shift between current and voltage)

Additional Error: $\pm 0.5\%$ of reading

Condition 6 - Temperature Variation

All conditions the same as Condition 1 except:

Ambient Temperature: -30°C to $+55^{\circ}\text{C}$

Accuracy: $\pm 0.5\%$ of reading

Logging

Data Records: 24186

Logging Interval: 1 minute to 720 minutes (12 hours)

Real-Time Clock

Accuracy: ± 2 minutes per year

Battery Capacity: 165 mAh

Battery Life: estimated 5 to 10 years

Fail-Safe Behavior: in the event of a battery failure, the WattNode will continue to keep time while power is applied and will remember the time during power outages, so if power fails for five minutes, the WattNode clock will be five minutes slow.

Electrical

Power Consumption: The following typical power consumption values are with all three phases powered. The WattNode's power supply draws most of the total power consumed, while the measurement circuitry draws 1-10% of the total (6-96 milliwatts per phase, depending on the model). Due to the design of the power supply, the WattNode draws more power at 50Hz.

Model	Active Power at Nominal VAC, 60Hz	Active Power at Nominal VAC, 50Hz	Typical Power Factor	Rated Power*
WNC-3Y-208-FT10-L	1.5W	1.8W	0.79	3W
WNC-3Y-400-FT10-L	1.6W	1.8W	0.73	3W
WNC-3Y-480-FT10-L	1.6W	2.0W	0.69	4W
WNC-3Y-600-FT10-L	1.0W	1.3W	0.76	3W
WNC-3D-240-FT10-L	1.2W	1.5W	0.70	4W
WNC-3D-400-FT10-L	1.1W	1.4W	0.67	3W
WNC-3D-480-FT10-L	1.2W	1.6W	0.70	4W

Table 9: WattNode Power Consumption

*Note: This is the maximum rated power at 115% of nominal VAC at 50Hz. This is the same as the rated power that appears on the front label of the WattNode.

Maximum Operating Voltage Range: -20% to +15% of nominal

Operating Frequencies: 50/60 Hz

Measurement Category: CAT III

Measurement category III is for measurements performed in the building installation. Examples are measurements on distribution boards, circuit-breakers, wiring, including cables, bus-bars, junction boxes, switches, socket-outlets in the fixed installation, and equipment for industrial use and some other equipment, for example, stationary motors with permanent connection to the fixed installation.

The line voltage measurement terminals on the WattNode are rated for the following CAT III voltages (these ratings also appear on the WattNode front label):

Model	CAT III Voltage Rating
WNC-3Y-208-FT10-L WNC-3D-240-FT10-L	240 VAC
WNC-3Y-400-FT10-L WNC-3D-400-FT10-L	400 VAC
WNC-3Y-480-FT10-L WNC-3D-480-FT10-L	480 VAC
WNC-3Y-600-FT10-L	600 VAC

Table 10: WattNode CAT III Ratings

Current Transformer Inputs:

Nominal Input Voltage: 0.333 VAC RMS

Absolute Maximum Input Voltage: 5.0 VAC RMS

Input Impedance at 50/60 Hz: 23k Ω

Recommended CT Wire Length: 2.4m (8 feet)

Communication

Transceiver: Echelon TP/FT-10

Bit Rate: 78 kbps

Maximum Nodes: 64 per subnet

Maximum Distance: 500–2700 meters (see [Connecting LonWorks Network Wiring](#) above)

Maximum Stub Length:

Free Topology: Unlimited

Bus Topology: 3 meters

Certifications

Safety: UL 61010-1; CAN/CSA-C22.2 No. 61010-1-04; IEC 61010-1

Emissions: FCC Part 15, Class B; EN 55022: 1994, Class B

Environmental

Operating Temperature: -30°C to +55°C (-22°F to 131°F)

Altitude: Up to 2000 m (6560 ft)

Operating Humidity: 5 to 90% relative humidity (RH) up to 40°C, decreasing linearly to 50% RH at 55°C.

Pollution: POLLUTION DEGREE 2 - Normally only non-conductive pollution; occasionally, a temporary conductivity caused by condensation must be expected.

Indoor Use: Suitable for indoor use.

Outdoor Use: Suitable for outdoor use when mounted inside an electrical enclosure (Hammond Mfg., Type EJ Series) that is rated NEMA 3R or 4.

Mechanical

Enclosure: High impact, ABS plastic

Flame Resistance Rating: 94V-0, IEC FV-0

Size: 143mm × 85mm × 38mm (5.63" × 3.34" × 1.5")

Weight: 320gm (11.3oz)

Connectors: Euroblock style pluggable terminal blocks

Green: 22 to 12 AWG (1.0mm - 3.2mm), 600 V

Black: 22 to 12 AWG (1.0mm - 3.2mm), 300 V

Warranty

All products sold by Continental Control Systems, LLC (CCS) are guaranteed against defects in material and workmanship for a period of three years from the date of shipment. CCS's responsibility is limited to repair, replacement, or refund, any of which may be selected by CCS at its sole discretion. CCS reserves the right to substitute functionally equivalent new or serviceable used parts.

WattNode Logger models include a lithium battery to preserve the date and time during power failures. CCS will replace or provide a replacement battery at no charge if the battery fails within five years from the date of shipment.

This warranty covers only defects arising under normal use and does not include malfunctions or failures resulting from: misuse, neglect, improper application, improper installation, water damage, acts of nature, lightning, or repairs by anyone other than CCS.

Except as set forth herein, CCS makes no warranties, expressed or implied, and CCS disclaims and negates all other warranties, including without limitation, implied warranties of merchantability and fitness for a particular purpose. Some states or jurisdictions do not allow limitations on implied warranties, so these limitations may not apply to you.

In no event shall CCS be liable for any indirect, special, incidental, or consequential damages. Some states or jurisdictions do not allow the exclusion or limitation of incidental or consequential damages, so the above exclusion or limitation may not apply to you.