

# *WATTNODE<sup>®</sup> PULSE*

## Installation and Operation Manual

- WNB-3Y-208-P
- WNB-3Y-400-P
- WNB-3Y-480-P
- WNB-3Y-600-P
- WNB-3D-240-P
- WNB-3D-400-P
- WNB-3D-480-P

Information in this document is subject to change without notice.

©2009 Continental Control Systems, LLC. All rights reserved.

Printed in the United States of America.

Document Number: WNB-P-2.40

Revision Date: Sept. 14, 2009

Continental Control Systems, LLC.

3131 Indian Rd., Suite A

Boulder, CO 80301

(303) 444-7422

FAX: (303) 444-2903

E-mail: [techsupport@ccontrolsys.com](mailto:techsupport@ccontrolsys.com)

Web: <http://www.ccontrolsys.com>

WattNode is a registered trademark of Continental Control Systems, LLC.

## **FCC Information**

This equipment has been tested and complies with the limits for a Class B digital device, pursuant to part 15 of the FCC Rules. Operation is subject to the following two conditions: (1) This device may not cause harmful interference, and (2) this device must accept any interference received, including interference that may cause undesired operation.

The FCC limits are designed to provide reasonable protection against harmful interference in a residential installation. This equipment generates, uses and can radiate radio frequency energy and, if not installed and used in accordance with the instructions, may cause harmful interference to radio communications. However, there is no guarantee that interference will not occur in a particular installation. If this equipment does cause harmful interference to radio or television reception, which can be determined by turning the equipment off and on, the user is encouraged to try to correct the interference by one or more of the following measures:

- Reorient or relocate the receiving antenna.
- Increase the separation between the equipment and receiver.
- Connect the equipment into an outlet on a circuit different from that to which the receiver is connected.
- Consult the dealer or an experienced radio/TV technician to help.

# Contents

---

<b>Overview .....</b>	<b>4</b>
Pulse Outputs.....	4
Diagnostic LEDs .....	4
Current Transformers.....	4
Additional Literature.....	4
Front Label.....	5
Symbols.....	6
<b>Installation .....</b>	<b>7</b>
Precautions .....	7
Electrical Service Types.....	8
Single-Phase Two-Wire with Neutral.....	8
Single-Phase Three-Wire.....	9
Single-Phase Two-Wire without Neutral.....	10
Three-Phase Four-Wire Wye.....	11
Three-Phase Three-Wire Delta (No Neutral).....	12
Mounting.....	13
Selecting Current Transformers .....	14
Connecting Current Transformers.....	15
Circuit Protection.....	16
Connecting Voltage Terminals.....	17
Connecting Pulse Outputs.....	17
Output Assignments.....	18
Pull-Up Resistor Selection .....	18
Installation Summary .....	19
Installation LED Diagnostics.....	20
Troubleshooting.....	23
<b>Operating Instructions.....</b>	<b>25</b>
Pulse Outputs.....	25
Power and Energy Computation .....	26
Power and Energy Equations.....	28
Maintenance and Repair.....	30
<b>Specifications .....</b>	<b>31</b>
Models.....	31
Current Transformers.....	32
Measurement .....	33
Accuracy.....	34
Pulse Outputs.....	34
Electrical .....	36
Certifications .....	37
Environmental.....	37
Mechanical.....	37
<b>Warranty.....</b>	<b>38</b>
Limitation of Liability .....	38

## Overview

---

Congratulations on your purchase of the WattNode® Pulse watt/watt-hour transducer. The WattNode offers precision energy and power measurements in a compact package. The WattNode enables you to make power and energy measurements from within existing electric service panels avoiding the costly installation of subpanels and associated wiring. It is designed for use in demand side management (DSM), sub-metering, and energy monitoring applications. The WattNode outputs a stream of pulses whose frequency is proportional to the instantaneous power and whose count is proportional to total watt-hours. Models are available for single-phase, three-phase wye, and three-phase delta configurations for voltages from 120 VAC to 600 VAC at 50 and 60 Hz.

## Pulse Outputs

The WattNode generates pulse outputs using one or more optoisolators (also called photo-couplers). These provide 5000V of isolation using an LED and a photo-transistor. This allows the WattNode to be interfaced to monitoring or data logging hardware without concerns about interference, ground loops, shock hazard, etc.

The standard Pulse WattNode makes bidirectional power measurements (positive and negative power). It can be used for conventional power and energy measurement as well as for net metering and photovoltaic (PV) applications.

- **Option P3** - The per-phase measurement option measures two or three separate branch circuits with a single three-phase WattNode, saving money and space.
- **Option PV** - The photovoltaic option measures residential PV systems. One WattNode measures the bidirectional total house energy, and the PV (or wind) generated energy. See **Manual Supplement MS-10** for details.
- **Options DPO** - The dual positive outputs option behaves exactly like the standard bidirectional model, but with the addition of a second positive pulse output channel (on the **P3** output terminal). This allows the WattNode to interface to two devices, such as a display and a data logger. See **Manual Supplement MS-11** for details.

Custom pulse output frequencies are available for special applications.

## Diagnostic LEDs

The Pulse WattNode includes three diagnostic LEDs—one per phase. During normal operation, these LEDs flash on and off, with the speed of flashing roughly proportional to the power on each phase. The LEDs flash green for positive power, red for negative power, and yellow for low power factor. Other conditions are signaled with different LED patterns. See the **Installation LED Diagnostics** section for full details.

## Current Transformers

The WattNode works with 0.333 VAC solid-core (toroidal), split-core (opening), and bus-bar current transformers (CTs). Split-core CTs offer greater ease of installation, because they can be installed without disconnecting the circuit being measured. Solid-core CTs are more compact, generally more accurate, and less expensive, but installation requires that the measured circuit be disconnected.

## Additional Literature

- WattNode Advanced Pulse - Quick Install Guide
- Manual Supplement MS-10 - Option PV (Photovoltaic)
- Manual Supplement MS-11 - Option DPO (Dual Positive Outputs)

## Front Label

This section describes all the connections, information, and symbols that appear on the WattNode front label.

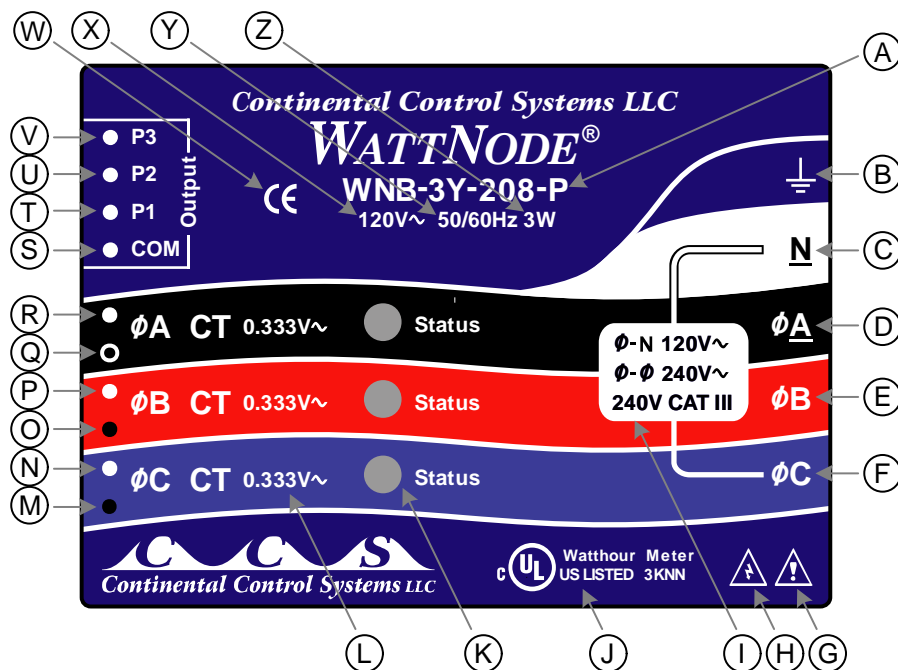





Figure 1: Front Label Diagram

- A: WattNode model number.** The “WNB” indicates a second generation WattNode with diagnostic LEDs and up to three pulse output channels. The “3” indicates a three phase model. The “Y” or “D” indicates wye (four-wire) or delta (three-wire) models, although delta WattNodes can measure wye circuits (the difference is in the power supply). The “208” (or other value) indicates the nominal phase-to-phase voltage. Finally, the “P” indicates pulse output.
- B: Functional ground.** This terminal should be connected to earth ground if possible. It is not required for safety grounding, but the accuracy of the WattNode may be reduced if this terminal is not connected.
- C: Neutral.** This terminal should be connected to neutral when available.
- D, E, F: Mains line inputs.** One or more of these terminals are connected to the mains lines. For three phase measurement, the  $\phi A$  (phase A),  $\phi B$  (phase B), and  $\phi C$  (phase C) terminals are used for the three phases. On delta WattNode models, the WattNode gets power from the  $\phi A$  and  $\phi B$  terminals.
- G: Attention - consult Installation and Operation Manual.** This symbol indicates that there can be danger when installing and operating the WattNode if the installation instructions are not followed correctly.
- H: Caution, risk of electrical shock.** This symbol indicates that there is a risk of electric shock when installing and operating the WattNode if the installation instructions are not followed correctly.
- I: Line voltage measurement ratings.** This block lists the nominal phase-to-neutral “ $\phi-N 120V\sim$ ” voltage, phase-to-phase “ $\phi-\phi 240V\sim$ ” voltage, and the rated measurement voltage and category “240V CAT III” for this WattNode model. See the [Specifications](#) for more information about the measurement voltage and category.

- J: UL Listing mark.** This shows the UL and cUL (Canadian) listing mark and number “**3KNN**”.
- K: Status LEDs.** These are status LEDs used to verify and diagnose WattNode operation. See [Installation LED Diagnostics](#) for details.
- L: Current transformer (CT) voltage rating.** These markings “**0.333V~**” indicate that the WattNode must be used with current transformers that generate a full-scale output of 0.333 VAC (333 millivolts AC).
- M, N, O, P, Q, R: Current transformer (CT) inputs.** These indicate the positions of the screw terminals for the current transformers connections. Note the white and black circles at the left edge of the label: these indicate the color of the CT wire that should be inserted into the corresponding screw terminal.
- S: Pulse output common (COM).** This is the common terminal for all three pulse output channels. This terminal should always be more negative than the **P1**, **P2**, and **P3** terminals.
- T, U, V: Pulse outputs (P1, P2, P3).** These are the three pulse outputs. Different WattNode models use one, two, or all three of these. These terminals should always be positive relative to the common terminal.
- W: CE Mark.** This symbol appears on WattNode models that are sold in the European Union and indicates that the WattNode complies with the regulations of the European Union for Product Safety and Electro-Magnetic Compatibility.
- X: Mains supply rated voltage.** This marking indicates the rated supply voltage for this WattNode. The **V~** indicates AC voltage. For wye WattNode models, this voltage should appear between the **N** and **ØA** terminals. For delta WattNode models, this voltage should appear between the **ØA** and **ØB** terminals.
- Y: Mains frequencies.** This indicates the rated mains frequencies for the WattNode.
- Z: Maximum rated power.** This indicates the maximum power consumption in watts (active power) for this WattNode model.

## Symbols

	Attention - Consult Installation and Operation Manual	Read, understand, and follow all instructions in this Installation and Operation Manual including all warnings, cautions, and precautions before installing and using the product.
	Caution – Risk of Electrical Shock	Potential Shock Hazard from Dangerous High Voltage.
	CE Marking	Complies with the regulations of the European Union for Product Safety and Electro-Magnetic Compatibility. <ul style="list-style-type: none"> <li>• Low Voltage Directive – EN 61010-1: 2001</li> <li>• EMC Directive – EN 61327: 1997 + A1/1998 + A2/2001</li> </ul>

# Installation

---

## Precautions



### DANGER – HIGH VOLTAGE HAZARD

**WARNING** - These installation/servicing instructions are for use by qualified personnel only. To avoid electrical shock, do not perform any servicing other than that contained in the operating instructions unless you are qualified to do so.

Only qualified personnel or electricians should install the WattNode. Different models of the WattNode measure circuits with voltages from 120 VAC single-phase to 600 VAC three-phase. These voltages are lethal! Always adhere to the following checklist:

- 1) CCS recommends that a **licensed electrician** install the WattNode.
- 2) CCS recommends that the WattNode be installed either in an electrical enclosure (panel or junction box) or in a limited access electrical room.
- 3) Verify that circuit voltages and currents are within the proper range for the WattNode model.
- 4) Use only UL recognized current transformers (CTs) with built-in burden resistors, that generate 0.333 VAC (333 millivolts AC) at rated current. **Do not** use current output CTs such as 1 amp or 5 amp output models! See **Specifications - Current Transformers** for CT maximum input current ratings.
- 5) Ensure that the line voltage inputs to the WattNode have either fuses or circuit breakers on each voltage phase (not needed for the neutral wire). See **Circuit Protection** below for details.
- 6) Equipment must be disconnected from the HAZARDOUS LIVE voltage before access.
- 7) The terminal block screws are **not** insulated. Do not contact metal tools to the screw terminals if the circuit is live!
- 8) Do not place more than one line voltage wire in a screw terminal; use wire nuts instead. You may use more than one CT wire per screw terminal.
- 9) Before turning on power to the WattNode, ensure that all the wires are securely installed by tugging on each wire.
- 10) Do not install the WattNode where it may be exposed to temperatures below -30°C or above 55°C, excessive moisture, dust, salt spray, or other contamination. The WattNode requires an environment no worse than pollution degree 2 (normally only non-conductive pollution; occasionally, a temporary conductivity caused by condensation must be expected).
- 11) Do not drill mounting holes using the WattNode as a guide; the drill chuck can damage the WattNode screw terminals and metal shavings can fall into the connectors, causing an arc risk.
- 12) If the WattNode is installed incorrectly, the safety protections may be impaired.

## Electrical Service Types

Below is a list of service types, with connections and recommended WattNode models. Note: the WattNode ground connection improves measurement accuracy, but is not required for safety.

Model	Type	Phase to Neutral	Phase to Phase	Electrical Service Types
WNB-3Y-208-P	Wye	120 VAC	208–240 VAC	1 Phase 2 Wire 120V with neutral 1 Phase 3 Wire 120V/240V with neutral 3 Phase 4 Wire Wye 120V/208V with neutral
WNB-3Y-400-P	Wye	230 VAC	400 VAC	1 Phase 2 Wire 230V with neutral 3 Phase 4 Wire Wye 230V/400V with neutral
WNB-3Y-480-P	Wye	277 VAC	480 VAC	3 Phase 4 Wire Wye 277V/480V with neutral
WNB-3Y-600-P	Wye	347 VAC	600 VAC	3 Phase 4 Wire Wye 347V/600V with neutral
WNB-3D-240-P	Delta or Wye	120–140 VAC	208–240 VAC	1 Phase 2 Wire 208V (No neutral) 1 Phase 2 Wire 240V (No neutral) 1 Phase 3 Wire 120V/240V with neutral 3 Phase 3 Wire Delta 208V (No neutral) 3 Phase 4 Wire Wye 120V/208V with neutral 3 Phase 4 Wire Delta 120/208/240V with neutral
WNB-3D-400-P	Delta or Wye	230 VAC	400 VAC	3 Phase 3 Wire Delta 400V (No neutral) 3 Phase 4 Wire Wye 230V/400V with neutral
WNB-3D-480-P	Delta or Wye	277 VAC	480 VAC	3 Phase 3 Wire Delta 480V (No neutral) 3 Phase 4 Wire Wye 277V/480V with neutral 3 Phase 4 Wire Delta 240/415/480V with neutral

\*The wire count does NOT include ground. It only includes neutral (if present) and phase wires.

Table 1: WattNode Models

### Single-Phase Two-Wire with Neutral

This configuration is most often seen in homes and offices. The two wires are neutral and line. For these models, the WattNode is powered from the **N** and  $\phi A$  terminals.

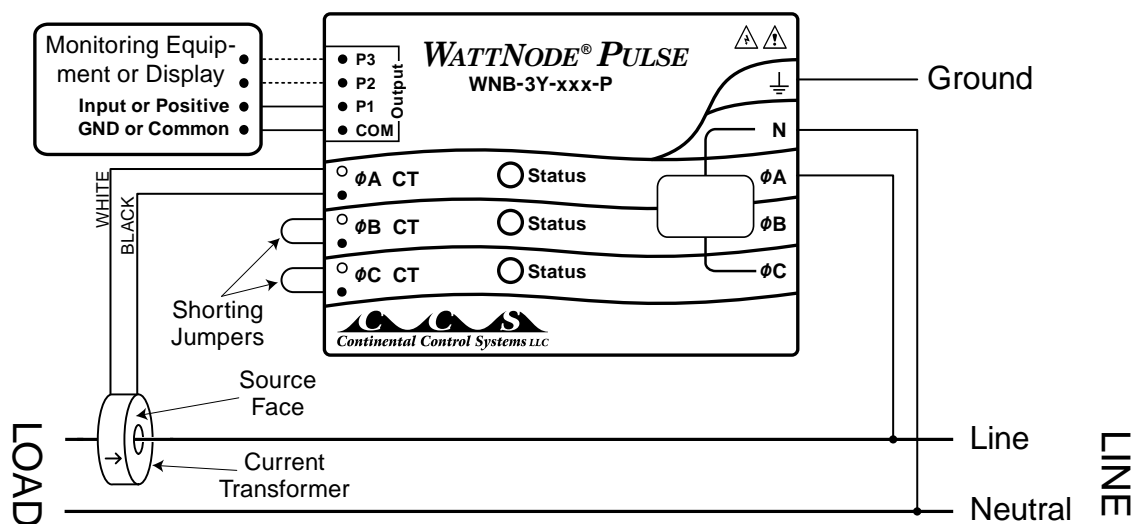

Figure 2: Single-Phase Two-Wire Connection

### Recommended WattNode Models

The following table shows the WattNode models that should be used, depending on the line to neutral voltage.

Line to Neutral Voltage	WattNode Model
120 VAC	WNB-3Y-208-P
230 VAC	WNB-3Y-400-P

### Single-Phase Three-Wire

This configuration is seen in North American residential and commercial service with 240 VAC for large appliances. The three wires are neutral and two line voltage wires with AC waveforms 180° out of phase; this results in 120 VAC between either line wire (phase) and neutral, and 240 VAC (or sometimes 208 VAC) between the two line wires (phases).

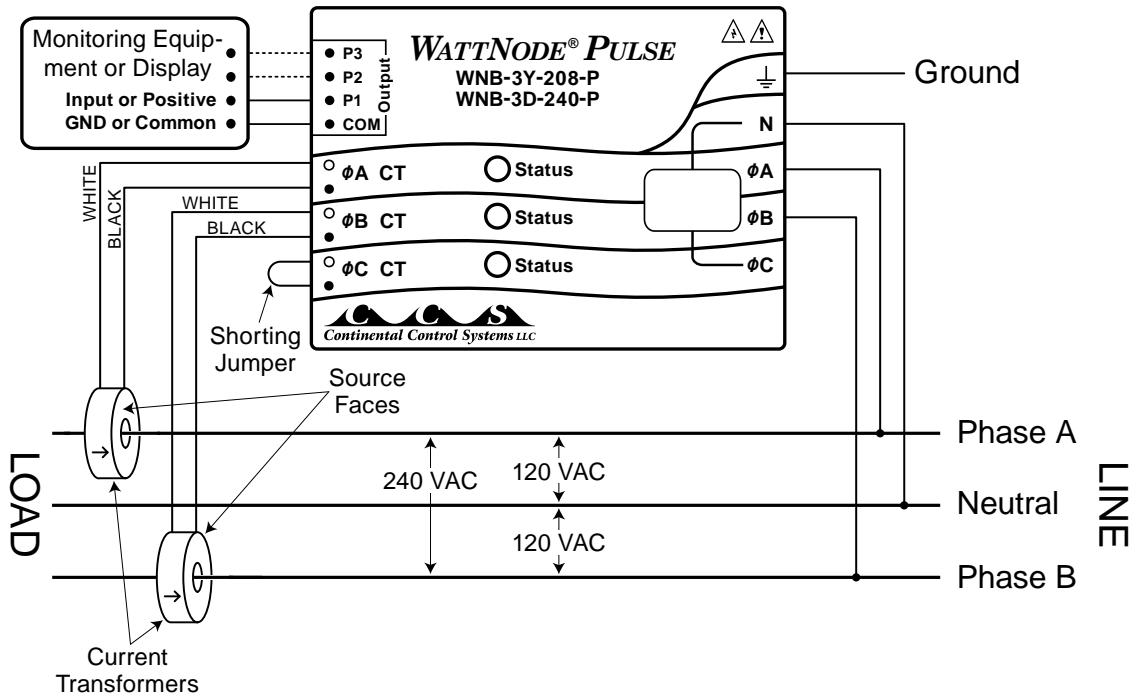

Figure 3: Single-Phase Three-Wire Connection

### Recommended WattNode Models

The following table shows the WattNode models that can be used. If neutral may or may not be present, you should use the WNB-3D-240-P (see **Single-Phase Two-Wire without Neutral** below). If neutral is present, it must be connected for accurate measurements. If phase B may not be present, you should use the WNB-3Y-208-P (see **Single-Phase Two-Wire with Neutral** above).

WattNode Power Source	WattNode Model
<b>N</b> and <b>φA</b> (Neutral and Phase A)	WNB-3Y-208-P
<b>φA</b> and <b>φB</b> (Phase A and Phase B)	WNB-3D-240-P

## Single-Phase Two-Wire without Neutral

This is seen in residential and commercial service with 208 to 240 VAC for large appliances. The two wires are two line voltage wires with AC waveforms 120° or 180° out of phase. Neutral is not used. This results in 240 VAC (or 208 VAC) between the two line wires (phases). For this configuration, the WattNode is powered from the  $\phi A$  and  $\phi B$  (phase A and phase B) terminals.

For best accuracy, we recommend connecting the WattNode **N** (neutral) terminal to earth ground. This will not cause ground current to flow because the neutral terminal is not used to power the WattNode.

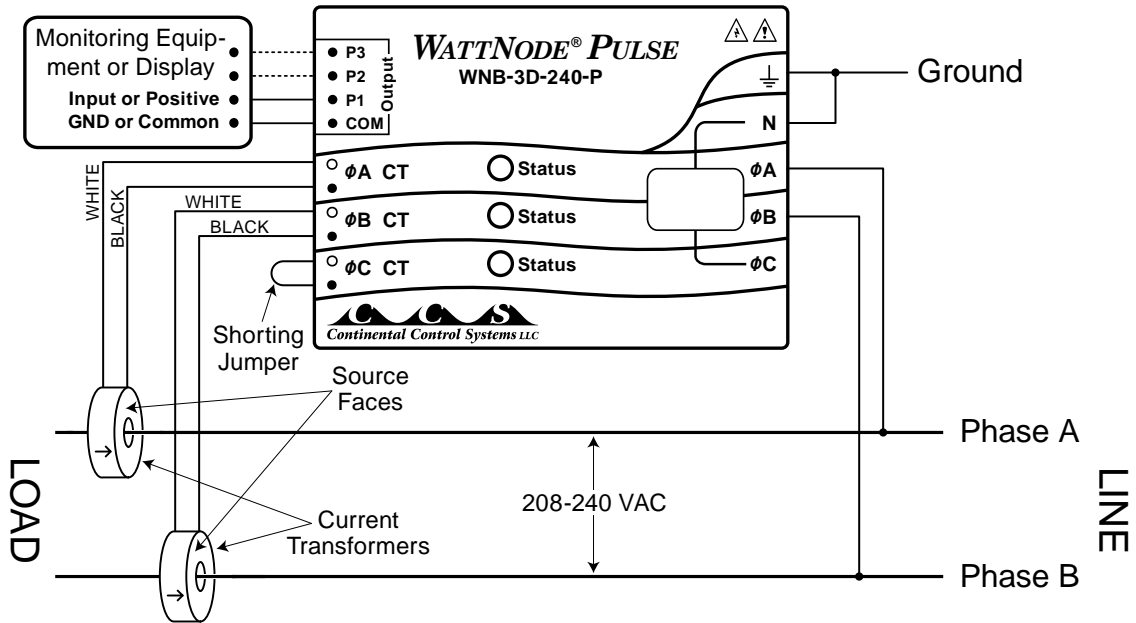

Figure 4: Single-Phase Two-Wire without Neutral Connection

### Recommended WattNode Model

This configuration is normally measured with one WattNode model.

Phase-to-Phase Voltage	WattNode Model
208 - 240 VAC	WNB-3D-240-P

However, if neutral is available, then you may also use the WNB-3Y-208-P model. If you use the WNB-3Y-208-P, you will need to hook up the WattNode as shown in section [Single-Phase Three-Wire](#) and connect neutral. You will need two CTs.

### Grounded Leg

In rare cases (non-residential), one of the lines (phase A or phase B) may be grounded. You can check for this by using a multimeter (DMM) to measure the voltage between each phase and ground. If you see a reading between 0 and 5 VAC, that leg (phase) is probably grounded.

The WattNode will correctly measure circuits with a grounded leg, but the measured voltage and power for the phase will be zero and the status LED will not light for whichever phase is grounded, because the voltage is near zero. If you have a grounded leg configuration, you can save money by removing the CT for the grounded phase, since all the power will be measured on the non-grounded phase. We recommend putting the grounded leg (phase) on the  $\phi B$  input and attaching a note to the WattNode indicating this configuration for future reference.

## Three-Phase Four-Wire Wye

This is typically seen in commercial and industrial environments. The wires are neutral and three power lines with AC waveforms shifted 120° between the successive phases. With this configuration, the line voltage wires may be connected to the  $\phi A$ ,  $\phi B$ , and  $\phi C$  terminals in any order, **so long as the CTs are connected to matching phases**. It is important that you connect **N** (neutral). For these models, the WattNode is powered from the **N** and  $\phi A$  terminals.

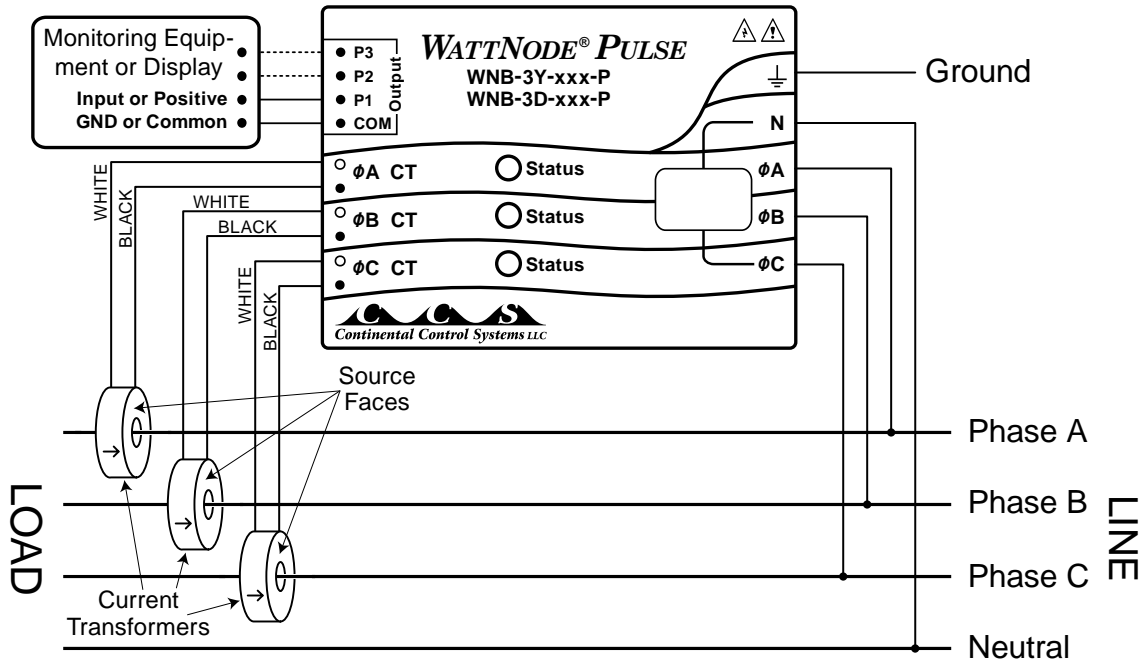

Figure 5: Three-Phase Four-Wire Wye Connection

### Recommended WattNode Models

The following table shows the WattNode models that should be used, depending on the line to neutral voltage and line to line voltage (also called phase to phase voltage).

Line to Neutral Voltage	Line to Line Voltage	WattNode Model
120 VAC	208 VAC	WNB-3Y-208-P
230 VAC	400 VAC	WNB-3Y-400-P
277 VAC	480 VAC	WNB-3Y-480-P
347 VAC	600 VAC	WNB-3Y-600-P

Note: you may also use the following delta WattNode models to measure three-phase four-wire wye circuits. The only difference is that delta WattNode models are powered from  $\phi A$  and  $\phi B$ , rather than **N** and  $\phi A$ . If neutral is present, it must be connected for accurate measurements.

Line to Neutral Voltage	Line to Line Voltage	WattNode Model
120 - 140 VAC	208 - 240 VAC	WNB-3D-240-P
230 VAC	400 VAC	WNB-3D-400-P
277 VAC	480 VAC	WNB-3D-480-P

## Three-Phase Three-Wire Delta (No Neutral)

This is typically seen in manufacturing and industrial environments. There is no neutral wire, just three power lines with AC waveforms shifted 120° between the successive phases. With this configuration, the line voltage wires may be connected to the  $\phi A$ ,  $\phi B$ , and  $\phi C$  terminals in any order, so long as the CTs are connected to matching phases. For these models, the WattNode is powered from the  $\phi A$  and  $\phi B$  (phase A and phase B) terminals. Note: all delta WattNode models provide a neutral connection **N**, which allows delta WattNode models to measure both wye and delta configurations.

For best accuracy, we recommend connecting the **N** (neutral) terminal to earth ground. This is not necessary on balanced three-phase circuits, where the ground-to-phase A, ground-to-phase B, and ground-to-phase C voltages are all roughly the same. This will not cause ground current to flow because the neutral terminal is not used to power the WattNode.

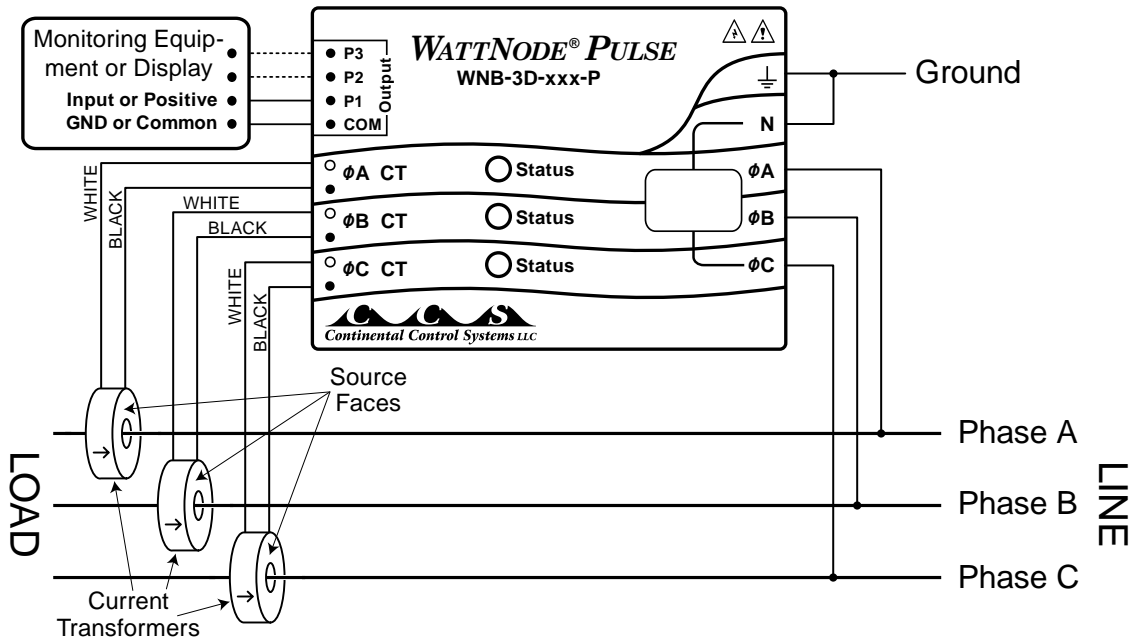

Figure 6: Three-Phase Three-Wire Delta Connection

### Recommended WattNode Models

The following table shows the WattNode models that should be used, depending on the line to line voltage (also called phase to phase voltage).

Line to Line Voltage	WattNode Model
208 - 240 VAC	WNB-3D-240-P
400 VAC	WNB-3D-400-P
480 VAC	WNB-3D-480-P

### Grounded Leg

In rare cases, one of the phases may be grounded. You can check for this by using a multimeter (DMM) to measure the voltage between each phase and ground. If you see a reading between 0 and 5 VAC, that leg is probably grounded.

The WattNode will correctly measure circuits with a grounded leg, but the measured voltage and power for the phase will be zero and the status LED will not light for whichever phase is grounded, because the voltage is near zero. Also, one or both of the active (non-grounded)

phases may show yellow or red/yellow LED flashing because the grounded leg configuration results in unusual power factors.

For optimum accuracy with a grounded leg, you should also connect the **N** (neutral) terminal on the WattNode to the ground terminal; this will not cause any ground current to flow because the neutral terminal is not used to power the WattNode. If you have a grounded leg configuration, you can save money by removing the CT for the grounded phase, since all the power will be measured on the non-grounded phases. We recommend putting the grounded leg on the  $\phi C$  (Phase C) input and attaching a note to the WattNode indicating this configuration for future reference.

## Mounting

Protect the WattNode from moisture, direct sunlight, high temperatures, and conductive pollution (salt spray, metal dust, etc.) If moisture or conductive pollution may be present, use an IP 66 or NEMA 4 rated enclosure to protect the WattNode. Due to its exposed screw terminals, the WattNode must be installed in an electrical service panel, a junction box, or an electrical room. The WattNode may be installed in any orientation, directly to a wall of an electrical panel or junction box.

The WattNode has two mounting holes spaced 127 mm (5.0 in) apart (center to center). These mounting holes are normally obscured by the detachable screw terminals. Remove the screw terminals by pulling outward while rocking from end to end. The WattNode or [Figure 7](#) may be used as a template to mark mounting hole positions, but **do not drill the holes with the WattNode in the mounting position** because the drill may damage the WattNode connectors and leave drill shavings in the connectors.

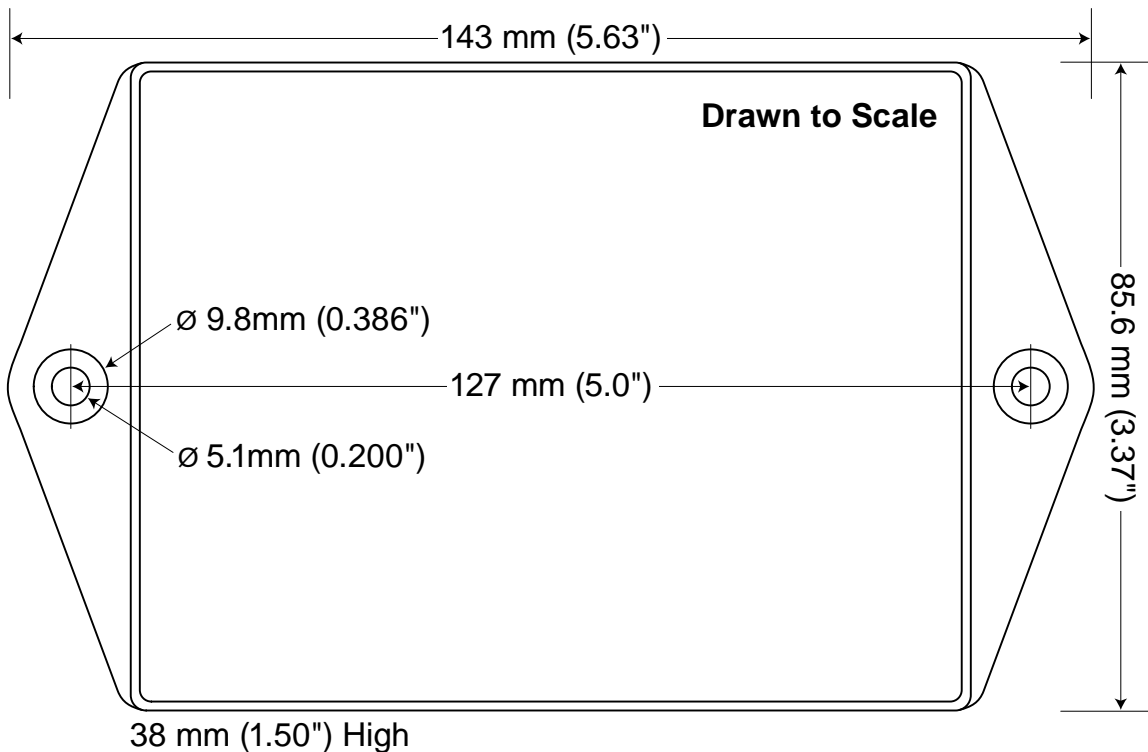

Figure 7: WattNode Dimensions

We recommend self tapping or self drilling sheet metal screws in the following sizes (**bold** are preferred).

Screw Style	U.S.A. UTS Sizes	Metric Sizes
Pan Head	#6, <b>#8</b> , #10	M3.5, <b>M4</b> , M5
Round Head	#6, <b>#8</b> , #10	M3.5, <b>M4</b> , M5
Truss Head	<b>#6</b> , #8	<b>M3.5</b> , M4
Hex Washer Head (integrated washer)	#6, <b>#8</b>	M3.5, <b>M4</b>
Hex Head (add washer)	#6, <b>#8</b> , #10	M3.5, <b>M4</b> , M5

**Table 2: WattNode Mounting Screws**

To protect the WattNode’s case, use washers if the screws could pull through the mounting holes. Don’t over-tighten the screws, because long term stress on the case can cause cracking.

## Selecting Current Transformers

The rated current of the CTs should normally be chosen somewhat above the maximum current of the circuit being measured (see **Current Crest Factor** below for more details). In some cases, you might select CTs with a lower rated current to optimize accuracy at lower current readings. Take care that the maximum allowable current for the CT can not be exceeded without tripping a circuit breaker or fuse (see **Specifications - Current Transformers**).

We only offer AC current transformers. These cannot measure DC currents. Furthermore, significant DC currents can saturate the magnetic core, interfering with accurate AC current measurements. The vast majority of loads will only have AC current, but occasionally you may encounter devices that draw DC current and may not be measured correctly. The most common sources of DC are devices that only use half cycles of AC current, resulting in large effective DC currents. Examples of devices that may cause DC currents include heat guns, hair dryers, and electric instant hot water heaters.

CTs can measure lower currents than they were designed for by passing the wire through the CT more than once. For example, to measure currents up to 1 amp with a 5 amp CT, loop the wire through the CT five times. The CT is now effectively a 1 amp CT instead of a 5 amp CT. The effective current rating of the CT is the labeled rating divided by the number of times that the wire passes through the CT.

### Current Crest Factor

The term “current crest factor” is used to describe the ratio of the peak current to the RMS current. Resistive loads like heaters and incandescent lights have nearly sinusoidal current waveforms with a crest factor near 1.4. Power factor corrected loads like PC power supplies typically have a crest factor of 1.4 to 1.5. Many common loads can have current crest factors ranging from 2.0 to 3.0, and higher values are possible.

The WattNode current transformer inputs will saturate and become inaccurate if the peak current is too high. This means you may want to be conservative in selecting the CT rated current. For example, if your load draws 10 amps RMS, but has a crest factor of 3.0, then the peak current is 30 amps. If you use a 15 amp CT, the WattNode will not be able to accurately measure the 30 amp peak current. **Note:** this is a limitation of the WattNode measurement circuitry, not the CT.

The following graph shows the maximum RMS current for accurate WattNode measurements as a function of the current waveform crest factor. The current is shown as a percentage of CT rated current. For example, if you have a 10 amp load with a crest factor of 2.0, the maximum CT current is approximately 85%. 85% of 15 amps is 12.75, which is higher than 10 amps, so your measurements should be accurate. On the other hand, if you have a 40 amp load with a crest factor of 4.0, the maximum CT current is 42%. 42% of a 100 amp CT is 42 amps, so you would need a 100 amp CT to accurately measure this 40 amp load.

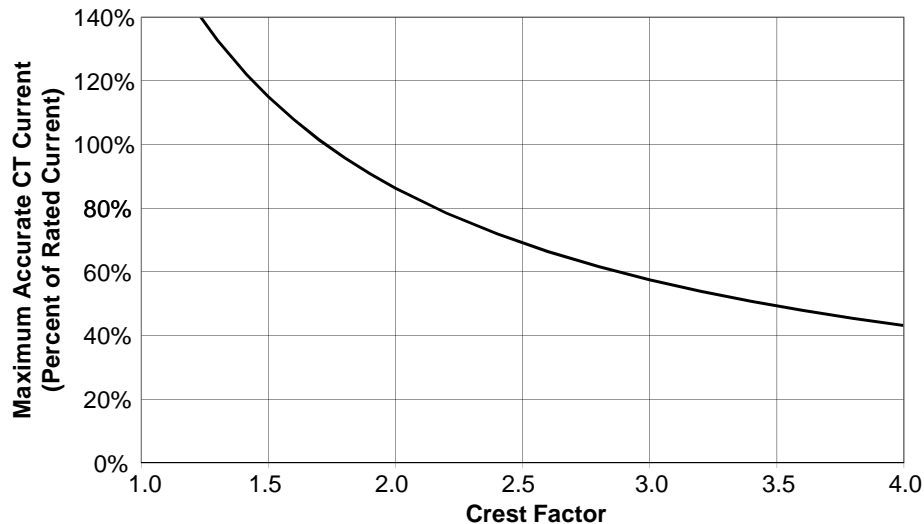

**Figure 8: Maximum CT Current vs. Crest Factor**

You frequently won't know the crest factor for your load. In this case, it's generally safe to assume the crest factor will fall in the 1.4 to 2.5 range and select CTs with a rated current roughly 150% of the expected RMS current. So if you expect to be measuring currents up to 30 amps, select a 50 amp CT.

## Connecting Current Transformers

- Use only UL recognized current transformers (CTs) with built-in burden resistors that generate 0.333 VAC (333 millivolts AC) at rated current. See [Specifications - Current Transformers](#) for the maximum input current ratings.
- **Do not** use current output CTs such as 1 amp or 5 amp output models: they will destroy the WattNode and present a shock hazard!
- Find the arrow or label "THIS SIDE TOWARD SOURCE" on the CT and face toward the current source: generally the utility meter or the circuit breaker for branch circuits. If CTs are mounted backwards or with their white and black wires reversed the measured power will be negative. The WattNode indicates negative phase power with flashing red LEDs.
- Be careful to match up the current transformers to the voltage phases being measured. Make sure the **ΦA CT** is measuring the line voltage connected to **ΦA**, and the same for phases B and C. It may help to use colored tape or labels to identify the wires.
- To prevent magnetic interference, the CTs on different phases should be separated by 1 inch (25 mm). The line voltage conductors for each phase should be separated by at least 1 inch (25 mm) from each other and from neutral.
- For best accuracy, the CT opening shouldn't be more than 50% larger than the conductor. If the CT opening is much bigger than the conductor, position the conductor to stay centered in the opening.
- We recommend keeping CT wires short if possible because the CT signals are low-voltage and are susceptible to interference. It is generally better to install the WattNode near the conductors being measured instead of extending the CT wires. However, it is possible to extend the CT wires by 300 feet (100 m) or more by using shielded twisted-pair cable and by not running the CT wires close to high current or high voltage line conductors.
- OPTIONAL: if you see spurious readings on unused phases, jumper the unused CT inputs.

To connect CTs, pass the wire to be measured through the CT and connect the CT to the WattNode. **Always remove power before disconnecting any live wires.** Put the line wires through the CTs as shown in the section [Electrical Service Types](#). You may measure generated power by treating the generator as the source.

Solid-core CTs require that the wire be disconnected before passing it through the opening in the CT.

Split-core and bus-bar CTs can be opened for installation around a wire by pulling the removable section straight away from the rest of the CT; it may require a strong pull. Some CT models include thumb-screws to secure the opening. The removable section generally only fits one way, so match up the steel core pieces when closing the CT. If the CT seems to jam and will not close, the steel core pieces are probably not aligned correctly; DO NOT FORCE together. Instead, reposition or rock the removable portion until the CT closes without excessive force. A nylon cable tie can be secured around the CT to prevent inadvertent opening.

Next, connect the CTs to the WattNode terminals labeled **ΦA CT**, **ΦB CT**, and **ΦC CT**. Route the twisted black and white wires from the CT to the WattNode. We recommend trimming excess length from the wires to reduce the risk of interference. Strip or trim the wires to expose 1/4" (6 mm) of bare wire. The current transformers connect to the six position black screw terminal block. Connect each CT with the white wire aligned with the white dot on the label, and the black wire aligned with the black dot. Note the order in which the phases are connected, as the voltage phases **must** match the current phases for accurate power measurement.

Finally record the CT rated current as part of the installation record for each WattNode. If the wires being measured are passed through the CTs more than once, then the recorded rated CT current is divided by the number of times that the wire passes through the CT.

## Circuit Protection

The WattNode is considered “permanently connected equipment”, because it does not use a conventional power cord that can be easily unplugged. **Permanently connected equipment must have overcurrent protection and be installed with a means to disconnect the equipment.** A switch, disconnect, or circuit breaker may be used to disconnect the WattNode. If a switch or disconnect is used, then there must also be a fuse or circuit breaker of appropriate rating protecting the WattNode.

The WattNode only draws 10-30 milliamps, so the rating of any switches, disconnects, fuses, and/or circuit breakers is determined primarily by the wire gauge used, the mains voltage, and the current interrupting rating required.

- The switch, disconnect, or circuit breaker used to disconnect the WattNode must be as close as practical to the WattNode.
- CCS recommends using circuit breakers or fuses rated for between 0.5 amps and 20 amps and rated for the mains voltages being measured.
- The overcurrent protection device (circuit breakers or fuses) must protect the ungrounded supply conductors (the mains terminals labeled **ΦA**, **ΦB**, and **ΦC**). If neutral is protected by the overcurrent protection device, then the overcurrent protection device must interrupt both neutral and the ungrounded conductors simultaneously.
- Any switches or disconnects should have at least a 1 amp rating and must be rated for the mains voltages being measured.
- The circuit protection / disconnect system must meet IEC 60947-1 and IEC 60947-3, as well as all national and local electrical codes.
- The line voltage connections should be made with wire rated for use in a service panel or junction box with a voltage rating sufficient for the highest voltage present. CCS recommends 14 or 12 AWG (1.5 mm<sup>2</sup> or 2.5 mm<sup>2</sup>) stranded wire, rated for 300V or 600V. Solid wire may be used, but must be routed carefully to avoid putting excessive stress on the pluggable screw terminal.
- The WattNode has an earth connection, which should be connected for maximum accuracy. However, this earth connection is not used for safety (protective) earthing.

## Connecting Voltage Terminals

**Always disconnect power**—by shutting off circuit breakers or removing fuses—before connecting the voltage lines to the WattNode. Connect each WattNode voltage input (green terminal block) to the appropriate phase; also connect ground and neutral (if applicable).

So long as the phase voltages are the same, the WattNode voltage inputs do not need to be connected to the same branch circuit as the load being monitored. In other words, if you have a three-phase panel with a 100A three-phase breaker powering a motor that you wish to monitor, you can power the WattNode (or several WattNodes) from a separate low current (20A) three-phase breaker in the same panel.

When connecting the WattNode, do not place more than one voltage wire in a screw terminal; use separate wire nuts or terminal blocks if needed. The screw terminals handle wire up to 12 AWG (2.5 mm<sup>2</sup>). Prepare the voltage wires by stripping the wires to expose 1/4" (6 mm) of bare wire. Connect each voltage line to the green terminal block as shown in the section **Electrical Service Types**. **Verify that the voltage line phases match the CT phases.** After the voltage lines have been connected, make sure both terminal blocks are securely installed on the WattNode.

If there is any doubt that the voltage rating of the WattNode is correct for the circuit being measured, then before applying power to the WattNode, disconnect the green screw terminal from the WattNode and then turn on the power. Use a voltmeter to measure the voltages (touch the screw heads) and verify that they match the values in the white box on the label.

When power is first applied to the WattNode, check that the LEDs behave normally: if you see the LEDs flashing red-green-red-green, then disconnect the power immediately! This indicates the line voltage is too high for the WattNode.

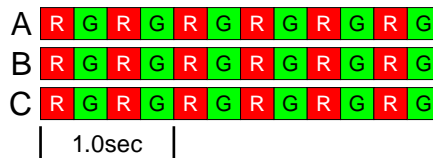

Figure 9: WattNode LED Overvoltage Warning

The WattNode is powered from the voltage inputs:  $\phi A$  (phase A) to **N** (neutral), or  $\phi A$  to  $\phi B$  for delta models. If the WattNode is not receiving at least 85% of the nominal line voltage, it may stop operating. Since the WattNode consumes a small amount of power itself, you may wish to power the WattNode from a separate circuit or place the current transformers downstream of the WattNode, so that the power from the WattNode is not measured.

## Connecting Pulse Outputs

- The outputs **P1**, **P2**, and **P3** should never be connected to negative voltages, or to voltages greater than +60 VDC.
- The recommended maximum current through the optoisolators is 5mA, although they will generally switch 8-10mA. If you need to switch higher currents, contact us about **Option SSR** (solid-state relay).
- The outputs are completely isolated from all dangerous voltages, so you can connect them at any time.
- Since the output wiring is near line voltage wiring, use wires or cables rated for the highest voltage present, generally 300V or 600V rated wire.
- If this cable will be in the presence of bare conductors, such as bus-bars, it should be double insulated or jacketed.
- When wiring over long distances, use shielded twisted-pair cable to prevent interference.

The WattNode's pulse outputs are the collector and emitter of an optoisolator transistor (also called a photocoupler) controlled by the WattNode's pulse stream. These outputs may be connected to most data monitoring devices that expect a contact closure or relay input: data loggers, energy management systems, etc. The following schematic illustrates connecting pull-up resistors on all three optoisolator outputs with a pull-up voltage of 5V.

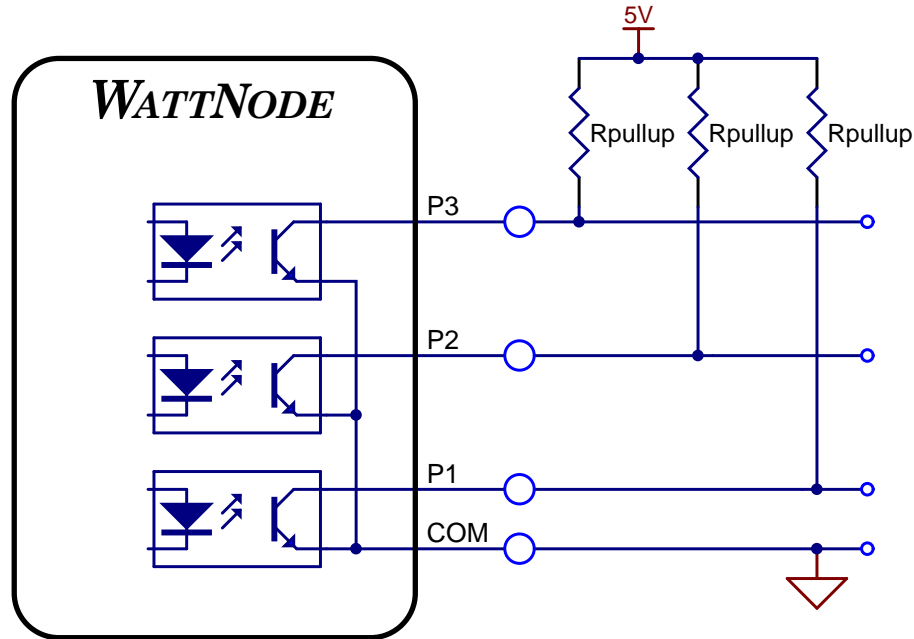

Figure 10: Optoisolator Outputs

The WattNode can have from one to three pulse output channels. All three output channels share the common **COM** or ground connection. Each output channel has its own positive output connection, labeled **P1**, **P2**, and **P3** (tied to the transistor collectors).

### Output Assignments

The following table shows the pulse output channel assignments for the standard bidirectional output WattNode and different options. See **Manual Supplement MS-10** for details about **Option PV**, and **Manual Supplement MS-11** for details about **Option DPO**.

WattNode Outputs	P1 Output	P2 Output	P3 Output
<b>Standard:</b> Bidirectional Outputs	Positive real energy (all phases)	Negative real energy (all phases)	Not used
<b>Option P3:</b> Per-Phase Outputs	Phase A positive real energy	Phase B positive real energy	Phase C positive real energy
<b>Option PV:</b> Photovoltaic	Phases A+B positive real energy	Phases A+B negative real energy	Phase C positive real energy
<b>Option DPO:</b> Dual Positive Outputs	Positive real energy (all phases)	Negative real energy (all phases)	Positive real energy (all phases)

Table 3: Pulse Output Assignments

### Pull-Up Resistor Selection

For standard WattNodes with the normal 4.00 Hz full-scale frequency, pull-up resistor values between 10kΩ and 100kΩ will work well. You can use values of 1.0MΩ or higher to reduce power consumption for battery powered equipment. **Note:** pull-up resistor values greater of 1.0MΩ or higher will make the pulse output signal more susceptible to picking up 50/60Hz or other

interference, so you may want to keep the wiring short, use shielded cable, and avoid running the pulse signal near AC wiring.

The following table lists pull-up resistor values (in ohms, kilo-ohms, and mega-ohms) to use with the WattNode pulse output(s), particularly if you have ordered a WattNode with a pulse frequency different than 4.00 Hz. For each configuration, the table lists a recommended value, followed by minimum and maximum resistor values. These values typically result in a pulse waveform rise time (from 20% to 80% of the pull-up voltage) of less than 10% of the total pulse period. The fall time is roughly constant in the 2 to 10 microsecond range. Lower resistance will result in faster switching and increase the current flow. If your frequency isn't in the table, use the next higher frequency or interpolate between two values.

Full-Scale Pulse Frequency	Pull-up to 3.0V Recommended (Min-Max)	Pull-up to 5.0V Recommended (Min-Max)	Pull-up to 12V Recommended (Min-Max)	Pull-up to 24V Recommended (Min-Max)
1 Hz	470kΩ (600Ω-4.7M)	470kΩ (1.0k-5.6M)	470kΩ (2.4k-7.5M)	1.0MΩ (4.7k-9.1M)
<b>4 Hz</b>	<b>100kΩ (600Ω-1.2M)</b>	<b>100kΩ (1.0k-1.6M)</b>	<b>100kΩ (2.4k-2.2M)</b>	<b>200kΩ (4.7k-3.0M)</b>
10 Hz	47kΩ (600Ω-470k)	47kΩ (1.0k-620k)	47kΩ (2.4k-910k)	100kΩ (4.7k-1.3M)
50 Hz	10kΩ (600Ω-91k)	10kΩ (1.0k-130k)	20kΩ (2.4k-200k)	47kΩ (4.7k-270k)
100 Hz	4.7kΩ (600Ω-47k)	4.7kΩ (1.0k-62k)	10kΩ (2.4k-100k)	20kΩ (4.7k-130k)
200 Hz	2.0kΩ (600Ω-24k)	2.0kΩ (1.0k-33k)	4.7kΩ (2.4k-47k)	10kΩ (4.7k-68k)
600 Hz	2.0kΩ (600Ω-8.2k)	2.0kΩ (1.0k-12k)	4.7kΩ (2.4k-16k)	10kΩ (4.7k-22k)

**Table 4: Recommended Pulse Output Pull-up Resistors**

When the optoisolator is on (conducting), there will be a small voltage drop between the common and output terminals, typically 0.1 - 0.4 volts, called the saturation voltage. This voltage depends on the current flowing through the optoisolator (see [Specifications - Optoisolator Outputs](#) below for details). To compute the current flowing through the optoisolator, use the following approximate equation:

$$I_{opto} = V_{pullup} / R_{pullup}$$

## Installation Summary

- 1) Mount the WattNode.
- 2) Turn off power before installing solid-core CTs or making voltage connections.
- 3) Mount the CTs around the line wires being measured. Take care to orient the CTs facing the source of power.
- 4) Connect the twisted white and black wires from the CT to the black terminal block on the WattNode, matching the wire colors to the white and black dots on the label of the WattNode.
- 5) Connect the voltage wires including ground and neutral (if present) to the green terminal block of the WattNode, and double check that the current measurement phases match the voltage measurement phases.
- 6) Connect the output terminals of the WattNode to the monitoring equipment.
- 7) Apply power to the WattNode.
- 8) Verify that the LEDs light correctly and don't indicate an error condition.

## Installation LED Diagnostics

The WattNode includes three multi-color power diagnostic LEDs (one for each phase) to help verify correct operation and diagnose incorrect installation. The LEDs are marked “Status” on the label. The following diagrams and descriptions explain the various LED patterns and their meanings. The A, B, and C on the left side indicate the phase of the LEDs. Values like “1.0s” and “3.0s” indicate the time the LEDs are lit in seconds. In the diagrams, sometimes the colors are abbreviated: R = red, G = green, Grn = green, Y = yellow.

### Normal Startup

On initial power-up, the LEDs will all light up in a red, yellow, green sequence. After this startup sequence, the LEDs will show the status, such as **Normal Operation** below.

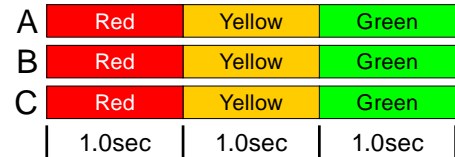

### Normal Operation

During normal operation, when positive power is measured on a phase, the LED for that phase will flash green. Typical flash rates are shown below.

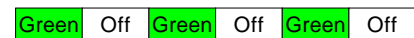

Percent of Full-Scale Power	LED Flash Rate	Flashes in 10 Seconds
100%	5.0 Hz	50
50%	3.6 Hz	36
25%	2.5 Hz	25
10%	1.6 Hz	16
5%	1.1 Hz	11
1% (and lower)	0.5 Hz	5

Table 5: LED Flash Rates vs. Power

### Zero Power

Below the minimum power that the WattNode can measure (see **Specifications - Measurement - Creep Limit**) as long as line VAC is present, the WattNode will display solid green for that phase.



### Inactive Phase

If the WattNode detects no power and line voltage below 20% of nominal, it will turn off the LED for the phase.

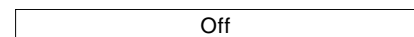

### Negative Power

If one or more of the phase LEDs are flashing red, it indicates negative power (power flowing into the grid) on those phases. The rate of flashing indicates magnitude of negative power (see **Table 5** above). This can happen for the following reasons:

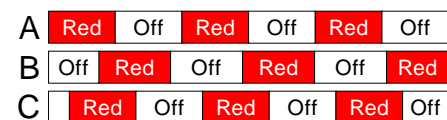

- This is a bidirectional power measurement application, such as a photovoltaic system, where negative power occurs whenever you generate more power than you consume.
- The current transformer (CT) for this phase was installed backwards on the wire or the white and black wires for the CT were reversed where they connect to the WattNode. This can be solved by flipping the CT on the wire or swapping the white and black wires at the WattNode.
- In some cases, this can also occur if the CT wires are connected to the wrong inputs on the WattNode, such as if the CT wires for phases B and C are swapped.

Note: if all three LEDs are flashing red and they always turn on and off together, like the diagram for **Low Line Voltage** below, then the WattNode is experiencing an error or low line voltage, not negative power.

## Low Power Factor

The WattNode will display yellow flashing or red/yellow flashing on any phase with low power factor. This may be normal for your load, or it may indicate that the CTs are not installed correctly.

Yellow	Off	Yellow	Off	Yellow	Off
Yellow	Red	Yellow	Red	Yellow	Red

Yellow flashing or red/yellow flashing indicates that the current lags the voltage by 60 degrees or more (power factor less than 0.5), or that the current leads the voltage by 30 degrees or more. Red/yellow also indicates negative power (energy flowing from the load to the grid). Yellow flashing (positive power) can happen for a variety of reasons, some of which occur during correct operation.

- Small appliances sometimes have low power factors.
- At light loads, motors, power supplies, and some other devices have low power factors.
- Traditional florescent light ballasts can have power factors as low as 0.4.
- Three-phase delta configurations can result in low power factors, especially if one of the phases is grounded.
- The CTs are not installed on the correct line phases. For example, if you connect phases A, B and C to the respective VAC inputs on the WattNode, but then the CTs for A, B, and C are connected in the wrong order to the WattNode, say B, A, C, then the power measured on phases A and B will have an extra 120 degree phase shift between voltage and current, resulting in a low power factor and probably negative power.

Red/yellow flashing (negative power) is less common and indicates incorrect installation unless you are generating power, as with PV (solar) power generation. When monitoring house (or building) power with PV (solar) power generation, the combination of the house load and the PV generated power can result in a net power with a low power factor.

In general, if you see yellow or yellow/red flashing for one or more phases check the following:

- Check that your load is turned on (since standby power supplies can have low power factors).
- Check that the CT phases match the phases for the VAC connections.
- Check that none of the CTs are installed backwards on the current carrying wire and that the white and black CT leads are installed in the correct screw terminals on the WattNode (the black wire should match up to the black circle on the label and the white wire should match up to the white circle on the label).
- Consider whether your load may have an unusual power factor. Loads like heaters, incandescent lights, and power factor corrected loads should have a power factor near 1.0 and should not cause the LEDs to flash yellow. Loads like motors, florescent light ballasts, etc. may have low power factors, in which case, yellow flashing may be normal.

## Erratic Flashing

If the LEDs are flashing slowly and erratically, sometimes green, sometimes red or yellow, this generally indicates one of the following:

- Earth ground is not connected to the WattNode (the top connection on the green screw terminal).
- Voltage is connected for a phase, but the current transformer is not connected, or the CT has a loose connection.

A	Off	Grn	Off	Red	Off
B	Red	Off	Yellow	Off	Red
C	Grn	Off	Red	Grn	Red

- In some cases, particularly for a circuit with no load, this may be due to electrical noise. This is not harmful and can generally be disregarded, provided that you are not seeing substantial measured power when there shouldn't be any. Try turning on the load to see if the erratic flashing stops.

To fix this, try the following:

- Make sure earth ground is connected.
- If there are unused current transformer inputs, install a shorting jumper for each unused CT (a short length of wire connected between the white and black dots marked on the label).
- If there are unused voltage inputs (on the green screw terminal), connect them to neutral (if present) or earth ground (if neutral isn't available).
- If you suspect noise may be the problem, try moving the WattNode away from the source of noise. Also try to keep the CT wires as short as possible and cut off excess wire.

### WattNode Not Operating

It should not be possible for all three LEDs to stay off when the WattNode is powered, because the phase powering the WattNode will have line voltage present. Therefore, if all LEDs are off, the WattNode is either not receiving sufficient line voltage to operate, or is malfunctioning and needs to be returned for service. Verify that the voltage on the VAC screw terminals is within  $\pm 20\%$  of the nominal operating voltages printed in the white rectangle on the front label.

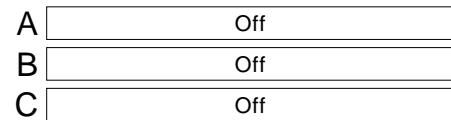

### WattNode Error

If the WattNode experiences an internal error, it will light all LEDs red for three seconds. If you see this happen repeatedly, return the WattNode for service.

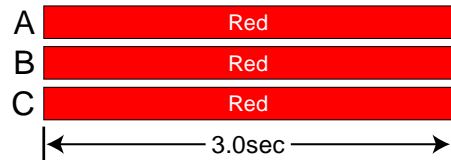

### Bad Calibration

This indicates that the WattNode has detected bad calibration data and must be returned for service.



### Line Voltage Too High

Whenever the WattNode detects line voltages over 125% of normal for one or more phases, it will display a fast red/green flashing for the affected phases. This is harmless if it occurs due a momentary surge, but if the line voltage is high continuously, **the power supply may fail. If you see continuous over-voltage flashing, disconnect the WattNode immediately!** Check that the WattNode model and voltage rating is correct for the circuit.

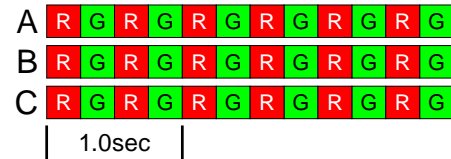

### Bad Line Frequency

If the WattNode detects a power line frequency below 45 Hz or above 70 Hz, it will light all the LEDs yellow for at least three seconds. The LEDs will stay yellow until the line frequency returns to normal. During this time, the WattNode should continue to accurately measure power.

This can occur in the presence of extremely high noise, such as if the WattNode is too close to an unfiltered variable frequency drive.



## Low Line Voltage

These LED patterns occur if the line voltage is too low for the WattNode to operate correctly and the WattNode reboots repeatedly. The pattern will be synchronized on all three LEDs. Verify that the voltage on the VAC screw terminals is no lower than 15% below the nominal operating voltages printed in the white rectangle on the front label. If the voltages are in the normal range and the WattNode continues to display one of these patterns, return the WattNode for service.

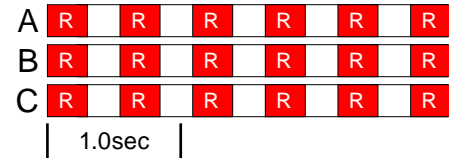
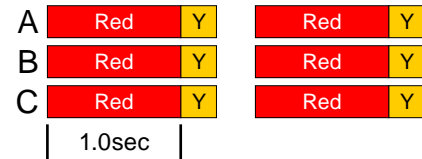

## Troubleshooting

If the WattNode does not appear to be operating correctly or generating expected pulses, start by checking the diagnostic LEDs as described in the previous section [Installation LED Diagnostics](#). Then double check the installation instructions. If there are still problems, check the following.

### No Pulses

- Make sure the load is turned on.
- If the LEDs are flashing green, then the WattNode is measuring positive power and should be generating pulses, so there may be something wrong with the pulse output connection or you may need a pull-up resistor (see [Connecting Pulse Outputs](#)).
- If the LEDs on one or more phases are flashing red or yellow/red, then the total power may be negative, in which case the WattNode won't generate positive energy pulses. If you have a bidirectional WattNode, you can check for negative energy pulses on the **P2** output. If this is the case, check that the line phases match the CT phases, that all the CTs face the source of power, and that the CT white and black wires are installed correctly at the WattNode.
- If all the LEDs are solid green (or off), then the measured power is below the creep limit (1/1500th of full-scale) and the WattNode will not generate any pulses (see [Specifications - Measurement - Creep Limit](#)).
- If the LEDs are flashing green slowly, the power may be very low. A WattNode with a nominal output frequency of 4.00 Hz can have a pulse period of several minutes at very low power levels.
- If all the LEDs are off, then the WattNode either does not have sufficient line voltage to operate, or has malfunctioned. Use a DMM (multimeter) to verify that the voltage on the VAC screw terminals is within -15%, +20% of the nominal operating voltage.

### Incorrect Power.

This can be caused by any of the following:

- An incorrect estimate of expected power. If possible, try to verify the actual power or current with a handheld power meter or current clamp.
- The CTs are not installed on the correct line phases. Verify that the CT phasing matches the line VAC inputs to the WattNode.
- The measured current exceeds the CT rating. This can saturate CT or the WattNode input circuitry, resulting in lower than expected readings. If possible, use a current clamp to measure the current and make sure it is below the CT rated amps.
- The measured current is too small. Most current transformers are only specified to meet their accuracy from 10% to 100% of rated current. In practice, most CTs work reasonably well down to 1% of rated current. Very low currents may not register properly, resulting in low power or no power reported.

- Interference from a variable frequency or variable speed drive: VFD, VSD, inverter, or the like. Generally, these drives should not interfere with the WattNode, but if they are in very close proximity, or if the CT leads are long, interference can occur. Try moving the WattNode at least one meter (three feet) away from any VFDs. Use short CT leads if possible. **NEVER** install the WattNode downstream of a VFD: the varying line frequency and extreme noise will cause problems!
- In rare cases, the CTs are defective or mislabeled. If possible, use a current clamp to verify the current, then use a DMM (multimeter) to measure the AC voltage between the white and black wires from the CT (leave them connected to the WattNode during this test). At rated current, the CT output voltage should equal 0.333 VAC (333 millivolts AC). At lower currents, the voltage should scale linearly, so at 20% of rated current, the output voltage should be  $0.20 * 0.333 = 0.0666$  VAC (66.6 millivolts AC).
- The WattNode is not functioning correctly: try swapping the WattNode for another unit.

# Operating Instructions

---

## Pulse Outputs

The WattNode generates pulse outputs using one or more optoisolators (also called photo-couplers). These provide 5000V of isolation using an LED and a photo-transistor. This allows the WattNode to be interfaced to monitoring or data logging hardware without concerns about interference, ground loops, shock hazard, etc.

Depending on the options selected, the Pulse WattNode can generate full-scale pulse output frequencies ranging from less than 1 Hz to 600 Hz. The standard full-scale output frequency is 4.00 Hz. The standard Pulse WattNode provides two pulse streams for measuring bidirectional power. With **Option P3**, the WattNode provides three pulse streams for independently measuring each phase or three single-phase circuits.

The pulse output(s) from the WattNode are generally square-waves, with equal on and off periods. The frequency of pulses is proportional to the measured power. When the measured power is constant, the pulse frequency is constant and the output is an exact square-wave. If the power is increasing or decreasing, the output waveform will not be a perfect square-wave as the on and off periods are getting longer or shorter.

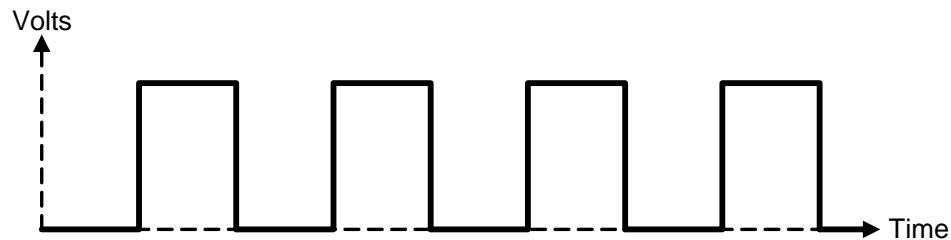

Figure 11: Output Pulses for Steady Power

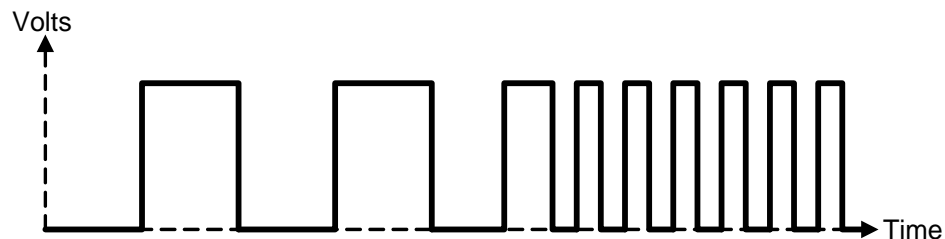

Figure 12: Output Pulses for Increasing Power

See [Connecting Pulse Outputs](#) (above) and [Specifications - Pulse Outputs](#) (below) for more information.

## Power and Energy Computation

Every pulse from the WattNode corresponds to a fixed amount of energy. Power (watts) is energy divided by time, which can be measured as pulses per second (or pulses per hour). The following scale factor tables and equations convert from pulses to energy (watt-hours or kilowatt-hours) for different models.

If you have ordered the WattNode with custom full-scale pulse output frequencies, then see the **Power and Energy Equations** section below. For **Option PV (Photovoltaic)**, see **Manual Supplement MS-10** for scale factors.

### Scale Factors - Standard Bidirectional Outputs

The following table provides scale factors for standard bidirectional output WattNode models with a full-scale pulse output frequency of 4.00 Hz. Equations to compute power and energy follow the scale factor tables.

CT Size (amps)	Pulses Per kilowatt-hour ( <i>PpKWH</i> )				Watt-hours per pulse ( <i>WHpP</i> )			
	3Y-208 3D-240	3Y-400 3D-400	3Y-480 3D-480	3Y-600	3Y-208 3D-240	3Y-400 3D-400	3Y-480 3D-480	3Y-600
5	8000.00	4173.91	3465.70	2766.57	0.125	0.2396	0.2885	0.3615
15	2666.67	1391.30	1155.24	922.190	0.375	0.7188	0.8656	1.0844
20	2000.00	1043.48	866.426	691.643	0.500	0.9583	1.1542	1.4458
30	1333.33	695.652	577.617	461.095	0.750	1.4375	1.7313	2.1688
50	800.000	417.391	346.570	276.657	1.250	2.3958	2.8854	3.6146
60	666.667	347.826	288.809	230.548	1.500	2.8750	3.4625	4.3375
70	571.429	298.137	247.550	197.612	1.750	3.3542	4.0396	5.0604
100	400.000	208.696	173.285	138.329	2.500	4.7917	5.7708	7.2292
150	266.667	139.130	115.523	92.219	3.750	7.1875	8.6563	10.844
200	200.000	104.348	86.643	69.164	5.000	9.5833	11.542	14.458
250	160.000	83.478	69.314	55.331	6.250	11.979	14.427	18.073
300	133.333	69.565	57.762	46.110	7.500	14.375	17.313	21.688
400	100.000	52.174	43.321	34.582	10.000	19.167	23.083	28.917
600	66.667	34.783	28.881	23.055	15.000	28.750	34.625	43.375
800	50.000	26.087	21.661	17.291	20.000	38.333	46.167	57.833
1000	40.000	20.870	17.329	13.833	25.000	47.917	57.708	72.292
1200	33.333	17.391	14.440	11.527	30.000	57.500	69.250	86.750
1500	26.667	13.913	11.552	9.2219	37.500	71.875	86.563	108.44
2000	20.000	10.435	8.6643	6.9164	50.000	95.833	115.42	144.58
3000	13.333	6.9565	5.7762	4.6110	75.000	143.75	173.13	216.88
any	$\frac{40,000}{CtAmps}$	$\frac{20,870}{CtAmps}$	$\frac{17,329}{CtAmps}$	$\frac{13,833}{CtAmps}$	$\frac{CtAmps}{40}$	$\frac{CtAmps}{20.87}$	$\frac{CtAmps}{17.329}$	$\frac{CtAmps}{13.833}$

Table 6: Scale Factors - Bidirectional Outputs

## Scale Factors - Option P3: Per-Phase Outputs

The following table provides scale factors for **Option P3** WattNode models with a full-scale pulse output frequencies of 4.00 Hz for each phase. Note: with **Option P3**, different phases can use different CTs with different rated currents.

**WARNING: Only use this table if your WattNode has Option P3 (Per-Phase Outputs)!**

CT Size (amps)	Pulses Per kilowatt-hour (PpKWH)				Watt-hours per pulse (WHpP)			
	3Y-208 3D-240	3Y-400 3D-400	3Y-480 3D-480	3Y-600	3Y-208 3D-240	3Y-400 3D-400	3Y-480 3D-480	3Y-600
5	24000.0	12521.7	10397.1	8299.71	0.04167	0.07986	0.09618	0.12049
15	8000.00	4173.91	3465.70	2766.57	0.1250	0.2396	0.2885	0.3615
20	6000.00	3130.43	2599.28	2074.93	0.1667	0.3194	0.3847	0.4819
30	4000.00	2086.96	1732.85	1383.29	0.2500	0.4792	0.5771	0.7229
50	2400.00	1252.17	1039.71	829.971	0.4167	0.7986	0.9618	1.2049
60	2000.00	1043.48	866.426	691.643	0.5000	0.9583	1.1542	1.4458
70	1714.29	894.410	742.651	592.837	0.5833	1.1181	1.3465	1.6868
100	1200.00	626.087	519.856	414.986	0.8333	1.5972	1.9236	2.4097
150	800.000	417.391	346.570	276.657	1.2500	2.3958	2.8854	3.6146
200	600.000	313.043	259.928	207.493	1.6667	3.1944	3.8472	4.8194
250	480.000	250.435	207.942	165.994	2.0833	3.9931	4.8090	6.0243
300	400.000	208.696	173.285	138.329	2.5000	4.7917	5.7708	7.2292
400	300.000	156.522	129.964	103.746	3.3333	6.3889	7.6944	9.6389
600	200.000	104.348	86.643	69.164	5.0000	9.5833	11.542	14.458
800	150.000	78.261	64.982	51.873	6.6667	12.778	15.389	19.278
1000	120.000	62.609	51.986	41.499	8.3333	15.972	19.236	24.097
1200	100.000	52.174	43.321	34.582	10.000	19.167	23.083	28.917
1500	80.000	41.739	34.657	27.666	12.500	23.958	28.854	36.146
2000	60.000	31.304	25.993	20.749	16.667	31.944	38.472	48.194
3000	40.000	20.870	17.329	13.833	25.000	47.917	57.708	72.292
any	<u>120,000</u> <b>CtAmps</b>	<u>62,609</u> <b>CtAmps</b>	<u>51,986</u> <b>CtAmps</b>	<u>41,499</u> <b>CtAmps</b>	<b>CtAmps</b> 120.00	<b>CtAmps</b> 62.609	<b>CtAmps</b> 51.986	<b>CtAmps</b> 41.499

Table 7: Scale Factors - Per-Phase Outputs (Option P3)

## Scale Factor Equations

Using the “Watt-hours per pulse” **WHpP** value from the table above for your WattNode model and current transformer, you can compute energy and power as follows:

- **PulseCount** - This is the count of pulses, used to compute energy. You can use the count of pulses over specified periods of time (like a month) to measure the energy for that period of time.
- **PulseFreq** - This is the measured pulse frequency (Hertz) out of the WattNode. This can also be computed by counting the number of pulses in a fixed period of time and then dividing by the number of seconds in that time period. For example, if you count 720 pulses in five minutes (300 seconds), then **PulseFreq** = 720 / 300 = 2.40 Hz.

$$\text{Energy (watt-hours)} = \text{WHpP} \cdot \text{PulseCount}$$

$$\text{Power (watts)} = \text{WHpP} \cdot 3600 \cdot \text{PulseFreq}$$

To convert these values to kilowatt-hours and kilowatts, divide by 1000.

Using the “Pulses Per kilowatt-hour” **PpKWH** value from the table above for your WattNode model and current transformer, you can compute energy and power as follows (multiply by 1000 to convert kilowatts to watts):

$$\text{Energy (kilowatt-hours)} = \text{PulseCount} / \text{PpKWH}$$

$$\text{Power (kilowatts)} = 3600 \cdot \text{PulseFreq} / \text{PpKWH}$$

## Power and Energy Equations

The following description explains how to compute power and energy from the pulse output stream of a WattNode for any full-scale pulse output frequency. The power is proportional to the pulse frequency, while the energy is proportional to the count of pulses.

For these calculations, we use the following variables:

- **NVAC** - This is the **nominal** line voltage (phase to neutral) of the WattNode model. For delta WattNodes, this is a virtual voltage, since there may not be a neutral connection. Note: this is **not** the actual measured voltage.
- **PpPO** - “Phases per Pulse Output”. This is the number of WattNode voltage phases associated with a pulse output channel. This may be different than the number of phases you are monitoring.
  - **Standard** and **Option DPO** (Dual Positive Outputs): **PpPO** = 3
  - **Option P3** (Per-Phase Outputs): **PpPO** = 1
  - **Option PV** (Photovoltaic): **PpPO** = 2 for outputs **P1** and **P2**, **PpPO** = 1 for output **P3**
- **CtAmps** - This is the current transformer (CT) rated amps. Note: If the wires being measured are passed through the CTs more than once, then **CtAmps** is the rated CT current divided by the number of times that the wire passes through the CT.
- **FSHz** - This is the full-scale pulse frequency of the WattNode. It is 4.00 Hz, unless the WattNode was ordered with **Option Hz=xxx** where **xxx** specifies the full-scale pulse frequency.
- **PulseCount** - This is the count of pulses, used to compute energy. You can use the count of pulses over specified periods of time (such as a month) to measure the energy for that period of time.
- **PulseFreq** - This is the measured pulse frequency out of the WattNode. This can also be computed by counting the number of pulses in a fixed period of time and then dividing by the number of seconds in that time period. For example, if you count 720 pulses in five minutes (300 seconds), then **PulseFreq** = 720 / 300 = 2.40 Hz.

The values of the constant parameters are in the following table.

WattNode Models	NVAC	Standard FSHz Values
WNB-3Y-208-P	120	4.00 Hz
WNB-3Y-400-P	230	4.00 Hz
WNB-3Y-480-P	277	4.00 Hz
WNB-3Y-600-P	347	4.00 Hz
WNB-3D-240-P	120*	4.00 Hz
WNB-3D-400-P	230*	4.00 Hz
WNB-3D-480-P	277*	4.00 Hz

*\*Note: these are “virtual” phase-to-neutral voltages used for delta model power and energy computations.*

**Table 8: Power and Energy Parameters**

## Full-Scale Power Equation

The following equation computes the nominal full-scale power associated with a pulse output channel. For bidirectional output WattNode models, this is the full-scale power for all phases together. For per-phase output WattNodes, this is the full-scale power for a single phase. Note: use **VAC** value from [Table 8: Power and Energy Parameters](#) above.

$$\text{Full-Scale Power (W)} = \text{NVAC} \cdot \text{PpPO} \cdot \text{CtAmps}$$

## Power Equation

The following equation computes the power associated with a pulse output. The **PulseFreq** value may be measured or averaged over different time periods to compute the average power (also called demand). Note: use **NVAC** value from [Table 8](#) above.

$$\text{Power (W)} = \frac{\text{NVAC} \cdot \text{PpPO} \cdot \text{CtAmps} \cdot \text{PulseFreq}}{\text{FSHz}}$$

## Energy Equation

The following equation computes the energy (watt-hours) associated with a pulse output channel. By using the **PulseCount** for different periods of time (day, week, month, etc.), you can measure the energy over different time periods. You can convert this to kilowatt-hours by dividing by 1000. The 3600 term in the denominator converts from watt-seconds to watt-hours. Note: use **NVAC** value from [Table 8](#) above.

$$\text{Energy (WH)} = \frac{\text{NVAC} \cdot \text{PpPO} \cdot \text{CtAmps} \cdot \text{PulseCount}}{\text{FSHz} \cdot 3600}$$

## Pulses per Watt-Hour

$$\text{PpWH} = \frac{\text{FSHz} \cdot 3600}{\text{NVAC} \cdot \text{PpPO} \cdot \text{CtAmps}}$$

## Pulses Per Kilowatt-Hour

$$\text{PpKWH} = \frac{\text{FSHz} \cdot 3600 \cdot 1000}{\text{NVAC} \cdot \text{PpPO} \cdot \text{CtAmps}}$$

## Watt-Hours per Pulse

$$\text{WHpP} = \frac{\text{PpPO} \cdot \text{NVAC} \cdot \text{CtAmps}}{\text{FSHz} \cdot 3600}$$

## Watt-Hours per Pulse per CT Rated Amp

There is an alternate way of computing the energy reported by a WattNode using the variable **WHpPpA** (watt-hours per pulse per CT rated amp). If you multiply the **WHpPpA** by the amp rating of your CTs, the result will be the watt-hours measured each time the WattNode generates a pulse.

$$\text{EnergyPerPulse (WH)} = \text{WHpPpA} \cdot \text{CtAmps}$$

The standard **WHpPpA** values are listed in the following table. These only apply for WattNodes with a 4.00 Hz full-scale pulse frequency.

WattNode Models	Watt-Hours per Pulse per CT Rated Amp (FSHz = 4.00)	
	Standard and Option DPO Outputs	Option P3: Per-Phase Outputs
WNB-3Y-208-P	0.02500	0.008333
WNB-3Y-400-P	0.04792	0.01597
WNB-3Y-480-P	0.05771	0.01924
WNB-3Y-600-P	0.07229	0.02410
WNB-3D-240-P	0.02500	0.008333
WNB-3D-400-P	0.04792	0.01597
WNB-3D-480-P	0.05771	0.01924

**Table 9: Watt-Hours per Pulse per CT Rated Amp**

For example: a WNB-3Y-208-P with a full-scale pulse frequency of 4.00 Hz has a **WHpPpA** value of 0.0250. With 15 amp CTs, it will output one pulse for every 0.375 watt-hours.

$$(0.025) \cdot (15.0 \text{ amps}) = 0.375 \text{ watt-hours}$$

It is easy to use the **WHpPpA** value to compute energy:

$$\text{Energy (WH)} = \text{WHpPpA} \cdot \text{CtAmps} \cdot \text{PulseCount}$$

For non-standard models, you can compute **WHpPpA** as follows:

$$\text{WHpPpA} = \frac{\text{PpPO} \cdot \text{NVAC}}{\text{FSHz} \cdot 3600}$$

## Maintenance and Repair

The WattNode requires no maintenance. It contains no user serviceable or replaceable parts. There are no fuses or batteries in the WattNode. There are no specific tests that can be performed by the user, other than verifying correct operation with the status LEDs and pulse outputs.

The WattNode should not normally need to be cleaned, but if cleaning is desired, power must be disconnected first and a dry cloth or brush should be used.

The WattNode is not user serviceable. In the event of any failure, the WattNode must be returned for service. In the case of a new installation, follow the instructions in sections **Installation**, **LED Diagnostics** and **Troubleshooting** before returning the WattNode for service, to ensure that the problem is not connection related.

# Specifications

## Models

Model	Nominal VAC phase-to-neutral	Nominal VAC phase-to-phase	Phases	Wires
WNB-3Y-208-P	120	208–240	3	4
WNB-3Y-400-P	230	400	3	4
WNB-3Y-480-P	277	480	3	4
WNB-3Y-600-P	347	600	3	4
WNB-3D-240-P	120*	208–240	3	3–4
WNB-3D-400-P	230*	400	3	3–4
WNB-3D-480-P	277*	480	3	3–4

\*Note: the delta models have an optional neutral connection that may be used for measuring wye circuits. The delta WattNode models use the phase A and phase B connections to power the WattNode.

**Table 10: WattNode Models**

Any of these models are available with the following output options:

- **Bidirectional Outputs** - (*this is the standard model*) This model has two pulse output channels. **P1** generates pulses in proportion to the total real positive energy, while **P2** generates pulses in proportion to the total real negative energy. The individual phase energies are all added together every 200ms. If the result is positive, it is accumulated for the **P1** output, while if it is negative, it is accumulated for the **P2** output. If one phase has negative power (-100W), while the other two phases have positive power (+100W each), the negative phase will subtract from the positive phases, resulting in a net of 100W, causing pulses on **P1**, but no pulses on **P2**. There will only be pulses on **P2** if the sum of all three phases is negative.
- **Option P3: Per-Phase Outputs** - Models with this option have three pulse streams: **P1**, **P2**, and **P3**. Each pulse stream generates pulses in proportion to the real positive energy measured on one phase (phases A, B, and C respectively).
- **Option DPO: Dual Positive Outputs** - This option is like the standard model with bidirectional outputs, but with the addition of the **P3** output channel. The **P3** channel indicates positive real energy, just like the **P1** channel. This is intended for when the WattNode needs to be connected to two different devices, such as a display and a data logger. See **Manual Supplement MS-11** for details.
- **Option PV: Photovoltaic** - The photovoltaic option measures residential PV systems. One WattNode measures the bidirectional total house energy, and the PV (or wind) generated energy. See **Manual Supplement MS-10** for details.
- **Option Hz=nnn: Custom Pulse Frequency** - WattNodes are available with custom full-scale pulse output frequencies ranging from 0.01 Hz to 600 Hz (150 Hz maximum for **Options P3, DPO, and PV**). For custom frequencies, specify **Option Hz=nnn**, where *nnn* is the desired full-scale frequency. To specify different frequencies for **P1**, **P2**, and **P3**, use **Option Hz=rrr/sss/ttt**, where **P1** frequency = *rrr*, **P2** frequency = *sss*, **P3** frequency = *ttt*.
- **Option SSR: Solid State Relay Output** - Replaces the standard optoisolator outputs with solid state relays capable of switching 500mA at up to 40 VAC or ±60 VDC. See **Option SSR Outputs** for details.

## Current Transformers

The WattNode uses CTs with built-in burden resistors generating 0.333 VAC at rated AC current. The maximum input current rating is dependent on the CT frame size (see the tables below). Exceeding the maximum input current rating may damage CTs.

The WattNode should only be used with UL recognized current transformers, which are available from Continental Control Systems. Using non-approved transformers will invalidate the WattNode's UL listing. The following sections list approved UL recognized current transformers.

### Split-Core CTs

Also called "opening" current transformers. These are UL recognized under UL file number E96927: CTS-0750-xxx, CTS-1250-xxx, CTS-2000-xxx, where **xxx** indicates the full scale current rating between 0005 and 1500 amps.

The accuracy and phase angle of the split-core CTs are specified from 10% to 100% of rated AC current. These CTs do not measure DC current and the accuracy will be degraded in the presence of DC current. Some low current split-core CTs have unspecified phase angle errors. The following table shows the available split-core CTs. The CT suffix **xxx** is the rated current.

**CT Wire Length:** 2.4m (8 feet)

Model	Inside Diameter	Rated Amps	Accuracy / Phase Angle	Maximum Amps
CTS-0750-xxx	0.75" (19.0mm)	5, 15, 20, 30, 50	±1% / not spec.	200
CTS-0750-xxx	0.75" (19.0mm)	70, 100, 150	±1% / <2°	200
CTS-1250-xxx	1.25" (31.7mm)	70, 100	±1% / not spec.	600
CTS-1250-xxx	1.25" (31.7mm)	150, 200, 250, 300, 400, 600	±1% / <2°	600
CTS-2000-xxx	2.00" (50.8mm)	600, 800, 1000, 1200, 1500	±1% / <2°	1500

**Table 11: Split-core CTs**

### Split-Core Bus Bar CTs

Also called "opening" current transformers. This series of CTs is referred to as "bus bar" CTs because they are available in larger and custom sizes appropriate for use with bus bars or multiple large conductors. These are UL recognized under UL file number E325972: CTB-wwwXhhh-xxx, where **www** and **hhh** indicate the width and height in inches, and **xxx** indicates the full scale current rating.

The accuracy of the split-core bus bar CTs is specified from 10% to 100% of rated current. The phase angle is specified at 50% of rated current. These CTs do not measure DC current and the accuracy will be degraded in the presence of DC current. The following table shows the available split-core bus bar CTs.

**CT Wire Length:** 2.4m (8 feet)

Model	Opening	Rated Amps	Accuracy / Phase Angle	Maximum Amps
CTB-1.5X3.5-0600	1.5" x 3.5" (38.1mm x 88.9mm)	600	±1.5% / <1.5°	750
CTB-4.0X4.0-0800	4.0" x 4.0" (101.6mm x 101.6mm)	800	±1.5% / <1.5°	1000
CTB-4.0X4.0-1200	4.0" x 4.0" (101.6mm x 101.6mm)	1200	±1.5% / <1.5°	1500
CTB-4.0X4.0-2000	4.0" x 4.0" (101.6mm x 101.6mm)	2000	±1.5% / <1.5°	2500
CTB-4.5X4.0-3000	4.5" x 4.0" (114.3mm x 101.6mm)	3000	±1.5% / <1.5°	3750
CTB-wwwXhhh-xxxx	Custom (www by hhh inches)	xxxx	±1.5% / <1.5°	4000

**Table 12: Split-core Bus Bar CTs**

## Solid-Core CTs

Also called “toroid” or “donut” current transformers. These are UL recognized under UL file number E96927: CTT-0750-100N, CTT-1250-400N, CTT-0300-030N, CTT-0500-060N, CTT-1000-200N, CTT-0300-005N, CTT-0300-015N, CTT-0500-050N, CTT-0500-030N, CTT-0500-015N, CTT-0750-070N, CTT-0750-050N, CTT-0750-030N, CTT-1000-150N, CTT-1000-100N, CTT-1000-070N, CTT-1000-050N, CTT-1250-300N, CTT-1250-250N, CTT-1250-200N, CTT-1250-150N, CTT-1250-100N, CTT-1250-070N.

The accuracy of the solid-core CTs is specified from 10% to 100% of rated current. The phase angle error is specified at 50% of rated current. These CTs do not measure DC current and the accuracy will be degraded in the presence of DC current. The following table shows the available solid-core CTs. The CT suffix **xxx** is the rated current. The “N” at the end of the part number indicates a nickel core material, which is the only core material available for our solid-core CTs.

**CT Wire Length:** 2.4m (8 feet)

Model	Inside Diameter	Rated Amps	Accuracy / Phase Angle	Maximum Amps
CTT-0300-xxxN	0.30" (7.6mm)	5, 15, 20, 30	±1% / <1°	30
CTT-0500-xxxN	0.50" (12.7mm)	15, 20, 30, 50, 60	±1% / <1°	60
CTT-0750-xxxN	0.75" (19.0mm)	30, 50, 70, 100	±1% / <1°	100
CTT-1000-xxxN	1.00" (25.4mm)	50, 70, 100, 150, 200	±1% / <1°	200
CTT-1250-xxxN	1.25" (31.7mm)	70, 100, 150, 200, 250, 300, 400	±1% / <1°	400

**Table 13: Solid-core CTs**

## Measurement

**Creep Limit:** 0.067% (1/1500th) of full-scale. Whenever the apparent power (a combination of the real and reactive power values) for a phase drops below the creep limit, the output power (real) for the phase will be forced to zero. Also, if the line voltage for a phase drops below 20% of nominal VAC, the output power for the phase will be forced to zero. These limits prevent spurious pulses due to measurement noise.

**Update Rate:** ~200 milliseconds. Internally, the consumed energy is measured at this rate and used to update the pulse output rate.

**Start-Up Time:** approximately 500 milliseconds. The WattNode starts measuring power and generating pulses 500 milliseconds after AC voltage is applied

**Current Transformer Phase Angle Correction:** 1.0 degrees. Current transformers (CTs) typically have a phase angle error ranging from 0.5 degrees to 2.0 degrees. The WattNode is normally programmed with a phase angle correction of 1.0 degrees to provide good accuracy with typical CTs. Contact the factory for other phase angle correction values.

**Over-Voltage Limit:** 125% of nominal VAC. If the line voltage for one or more phases exceeds this limit, the status LEDs for these phases will flash alternating red-green as a warning. Extended over-voltage operation can damage the WattNode and void the warranty. See [Line Voltage Too High](#) in the [Installation LED Diagnostics](#) section.

## Accuracy

The following accuracy specifications do not include errors caused by the current transformers. "Rated current" is the current that generates a CT output voltage of 0.333 VAC.

### **Condition 1 - Normal Operation**

**Line voltage:** 80% - 115% of nominal

**Power factor:** 1.0

**Frequency:** 48 - 62 Hz

**Ambient Temperature:** 25°C

**Current:** 5% - 100% of rated current

**Accuracy:**  $\pm 0.5\%$  of reading

### **Condition 2 - Low Current**

All conditions the same as Condition 1 except:

**Current:** 1% - 5% of rated current

**Accuracy:**  $\pm 1.0\%$  of reading

### **Condition 3 - Very Low Current**

All conditions the same as Condition 1 except:

**Current:** 0.2% - 1% of rated current

**Accuracy:**  $\pm 3.0\%$  of reading

### **Condition 4 - High Current**

All conditions the same as Condition 1 except:

**Current:** 100% - 120% of rated current

**Accuracy:**  $\pm 1.0\%$  of reading

### **Condition 5 - Low Power Factor**

All conditions the same as Condition 1 except:

**Power factor:** 0.5 ( $\pm 60$  degree phase shift between current and voltage)

**Additional Error:**  $\pm 0.5\%$  of reading

### **Condition 6 - Temperature Variation**

All conditions the same as Condition 1 except:

**Ambient Temperature:** -30°C to +55°C

**Accuracy:**  $\pm 0.5\%$  of reading

*Note: Option PV WattNodes may not meet these accuracy specifications for the P3 output channel when measuring a two-phase inverter or multiple inverters.*

## Pulse Outputs

**Factory Programmable Full-Scale Pulse Frequencies:**

**Standard (All Models):** 4.00 Hz

**Custom (Bidirectional Output Models):** 0.01 Hz to 600 Hz

**Custom (Option P3, Option PV, Option DPO):** 0.01 Hz to 150 Hz

**Absolute Maximum Pulse Output Frequencies:**

**Standard Models (Bidirectional Outputs):** 900 Hz

**Option P3, Option PV, Option DPO:** 200 Hz

**Output Waveform:** square-wave, ~50% duty cycle

**Optoisolator Outputs:**

**Isolation:** 5000 VAC RMS

**Breakdown Voltage (collector-emitter):** 60 V (exceeding this may destroy the outputs)

**Maximum Reverse Voltage (emitter-collector):** 5V (exceeding this may destroy the outputs)

**Maximum Leakage (Off) Current (collector-emitter):** 100nA

**Recommended Load Current (collector-emitter):** 1µA (microamp) to 5mA (milliamp)

**Maximum Load (collector-emitter) Current:** ~8 mA

**Output Rise Time (microseconds):** approximately  $R_{pullup} / 100$ , where  $R_{pullup}$  is the pull-up resistor value (in ohms) and the pull-up voltage is 5V. Rise time is defined as the time for the output voltage to rise from 20% to 80% of the pull-up voltage.

**Output Fall Time:** approximately 2-3 microseconds with a 5V pull-up voltage.

**Saturation Voltage vs. Load Current:** this is the typical voltage (at room temperature) measured between the **COM** terminal and **P1**, **P2**, or **P3** when the optoisolator is on (conducting). Ideally, this voltage would be zero, but instead, it varies with the load current.

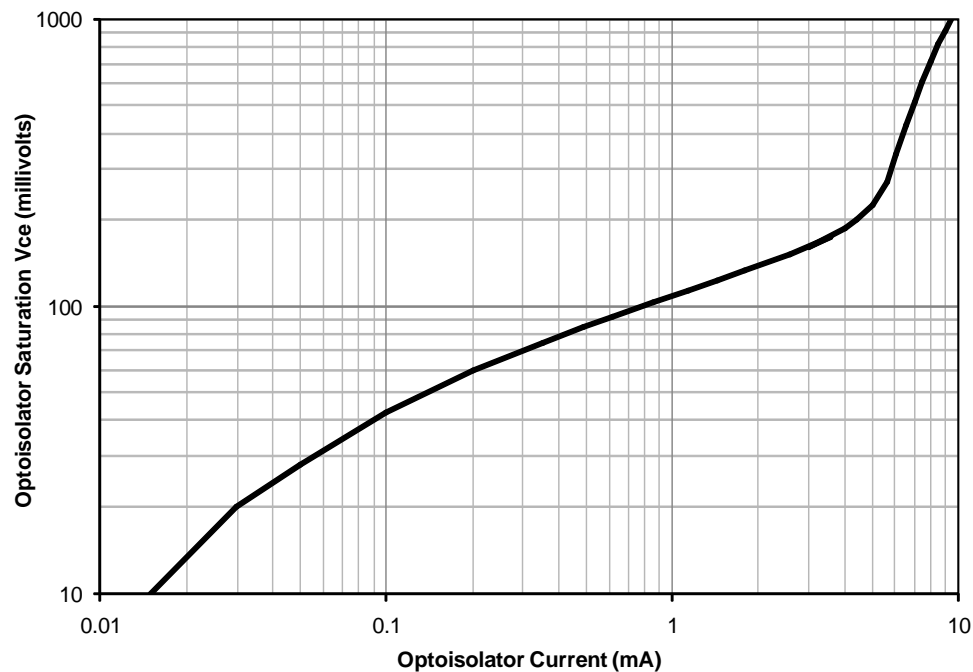

**Figure 13: Optoisolator Saturation Voltage vs. Load Current**

**Option SSR Outputs:**

**Isolation:** 5000 VAC RMS

**Breakdown Voltage:** ±60 VDC or 40 VAC; can switch positive, negative or AC voltages

**Maximum Leakage (Off) Current:** 1000nA (1µA)

**On Resistance:** 1.0 to 2.5 ohms

**Maximum Load Current:** 500 mA

**Output Turn On Time (milliseconds):** 1.8 ms typical, 5.0 ms maximum

**Output Turn Off Time (milliseconds):** 0.5 ms typical, 2.0 ms maximum

**Maximum Recommended Pulse Frequency:** 30 Hz

## Electrical

**Power Consumption:** The following typical power consumption values are with all three phases powered. The WattNode's power supply draws most of the total power consumed, while the measurement circuitry draws 1-10% of the total (6-96 milliwatts per phase, depending on the model). Due to the design of the power supply, the WattNode draws more power at 50Hz.

Model	Active Power at Nominal VAC, 60Hz	Active Power at Nominal VAC, 50Hz	Typical Power Factor	Rated Power*
WNB-3Y-208-P	1.6W	1.8W	0.75	3W
WNB-3Y-400-P	1.6W	1.8W	0.64	3W
WNB-3Y-480-P	2.1W	2.4W	0.63	4W
WNB-3Y-600-P	1.2W	1.2W	0.47	3W
WNB-3D-240-P	1.7W	1.9W	0.63	4W
WNB-3D-400-P	1.4W	1.5W	0.47	3W
WNB-3D-480-P	1.8W	2.2W	0.53	4W

**Table 14: WattNode Power Consumption**

*\*Note: This is the maximum rated power at 115% of nominal VAC at 50Hz. This is the same as the rated power that appears on the front label of the WattNode.*

**Maximum Operating Voltage Range:** -20% to +15% of nominal

**Operating Frequencies:** 50/60 Hz

**Measurement Category:** CAT III

Measurement category III is for measurements performed in the building installation. Examples are measurements on distribution boards, circuit-breakers, wiring, including cables, bus-bars, junction boxes, switches, socket-outlets in the fixed installation, and equipment for industrial use and some other equipment, for example, stationary motors with permanent connection to the fixed installation.

The line voltage measurement terminals on the WattNode are rated for the following CAT III voltages (these ratings also appear on the WattNode front label):

Model	CAT III Voltage Rating
WNB-3Y-208-P WNB-3D-240-P	240 VAC
WNB-3Y-400-P WNB-3D-400-P	400 VAC
WNB-3Y-480-P WNB-3D-480-P	480 VAC
WNB-3Y-600-P	600 VAC

**Table 15: WattNode CAT III Ratings**

**Current Transformer Inputs:**

**Nominal Input Voltage (At Rated Current):** 0.333 VAC RMS

**Absolute Maximum Input Voltage:** 5.0 VAC RMS

**Input Impedance at 50/60 Hz:** 23k $\Omega$

## Certifications

**Safety:** UL 61010-1; CAN/CSA-C22.2 No. 61010-1-04; IEC 61010-1

**Emissions:** FCC Part 15, Class B; EN 55022: 1994, Class B

**Immunity:** EN 61326: 2002 (Industrial Locations)

**Electrostatic Discharge:** EN 61000-4-2: (B) Self-Recovering

**Radiated RF Immunity:** EN 61000-4-3: (A) No Degradation

**Electrical Fast Transient / Burst:** EN 61000-4-4: (B) Self-Recovering

**Surge Immunity:** EN 61000-4-5: (B) Self-Recovering

**Conducted RF Immunity:** EN 61000-4-6: (A) No Degradation

**Voltage Dips, Interrupts:** EN 61000-4-11: (B) Self-Recovering

## Environmental

**Operating Temperature:** -30°C to +55°C (-22°F to 131°F)

**Altitude:** Up to 2000 m (6560 ft)

**Operating Humidity:** 5 to 90% relative humidity (RH) up to 40°C, decreasing linearly to 50% RH at 55°C.

**Pollution:** POLLUTION DEGREE 2 - Normally only non-conductive pollution; occasionally, a temporary conductivity caused by condensation must be expected.

**Indoor Use:** Suitable for indoor use.

**Outdoor Use:** Suitable for outdoor use when mounted inside an electrical enclosure (Hammond Mfg., Type EJ Series) that is rated NEMA 3R or 4 (IP 66).

## Mechanical

**Enclosure:** High impact, ABS plastic

**Flame Resistance Rating:** UL 94V-0, IEC FV-0

**Size:** 143 mm × 85 mm × 38 mm (5.63 in × 3.34 in × 1.5 in)

**Weight:** 285 gm (10.1 oz)

**Connectors:** Euroblock style pluggable terminal blocks

**Green:** up to 12 AWG (2.5 mm<sup>2</sup>), 600 V

**Black:** up to 12 AWG (2.5 mm<sup>2</sup>), 300 V

## Warranty

---

All products sold by Continental Control Systems, LLC (CCS) are guaranteed against defects in material and workmanship for a period of three years from the original date of shipment. CCS's responsibility is limited to repair, replacement, or refund, any of which may be selected by CCS at its sole discretion. CCS reserves the right to substitute functionally equivalent new or serviceable used parts.

This warranty covers only defects arising under normal use and does not include malfunctions or failures resulting from: misuse, neglect, improper application, improper installation, water damage, acts of nature, lightning, product modifications, alterations or repairs by anyone other than CCS.

**Except as set forth herein, CCS makes no warranties, expressed or implied, and CCS disclaims and negates all other warranties, including without limitation, implied warranties of merchantability and fitness for a particular purpose.**

## Limitation of Liability

In no event shall CCS be liable for any indirect, special, incidental, punitive or consequential damages of any kind or nature arising out of the sale or use of its products whether such liability is asserted on the basis of contract, tort or otherwise, including without limitation, lost profits, even if CCS has been advised of the possibility of such damages.

Customer acknowledges that CCS's aggregate liability to Customer relating to or arising out of the sale or use of CCS's products, whether such liability is asserted on the basis of contract, tort or otherwise, shall not exceed the purchase price paid by Customer for the products in respect of which damages are claimed. Customer specifically acknowledges that CCS's price for the products is based upon the limitations of CCS's liability set forth herein.